

19" Sample Gas Conditioning System SCS



The Bühler Model SCS Sample Gas Conditioner is a pre-engineered, pre-packaged sampling system including all pneumatic components that are normally used in gas analysis systems. The SCS integrates the following pneumatic functions: sample pump, sample cooler, calibration gas valves, flow meters, condensate drains, particulate filtration, and operator interface, PLC or data logger control features all into a single 19" rack-mount enclosure.

The design concept emphasizes modularity allowing easy and cost effective configuration to different applications. The SCS may be controlled manually or externally. System status is shown on the front panel and may be output to external devices.

To create a complete analysis system, a probe, a heated sample line and an analyzer can be added to the SCS. A PLC may also be used to automate the system. All parts requiring maintenance are easily accessible from the front panel.

Many variations and options are available for this unit depending on the specific requirements of the application.

Please contact one of our application specialists for further details on how the SCS Gas Conditioning system can be configured to meet your requirements.

- Includes all necessary gas conditioning components
- Modular design: very cost effective
- Installs easily: Rack mountable (plug and play)
- Low maintenance cost due to efficient design
- 1 or 2 gas paths
- 2 standard flow rates
- Up to 5 calibration gases
- Corrosion resistant materials available
- Optional acidification
- Manually or externally controlled
- Self surveillance
- A variety of connections are available

Description

There are six standard stock configurations of the SCS. However, due to the modular design of the SCS, the unit can be configured for a wide variety of flow and control options. As an example, the SCS 300 (shown on the first page) is described below. Drawings of the views and dimensions are shown on the last page. Not all of the described modules are required for all applications (e.g. the acidification).

Please contact one of our application specialists for detailed configuration information relevant to your specific application.

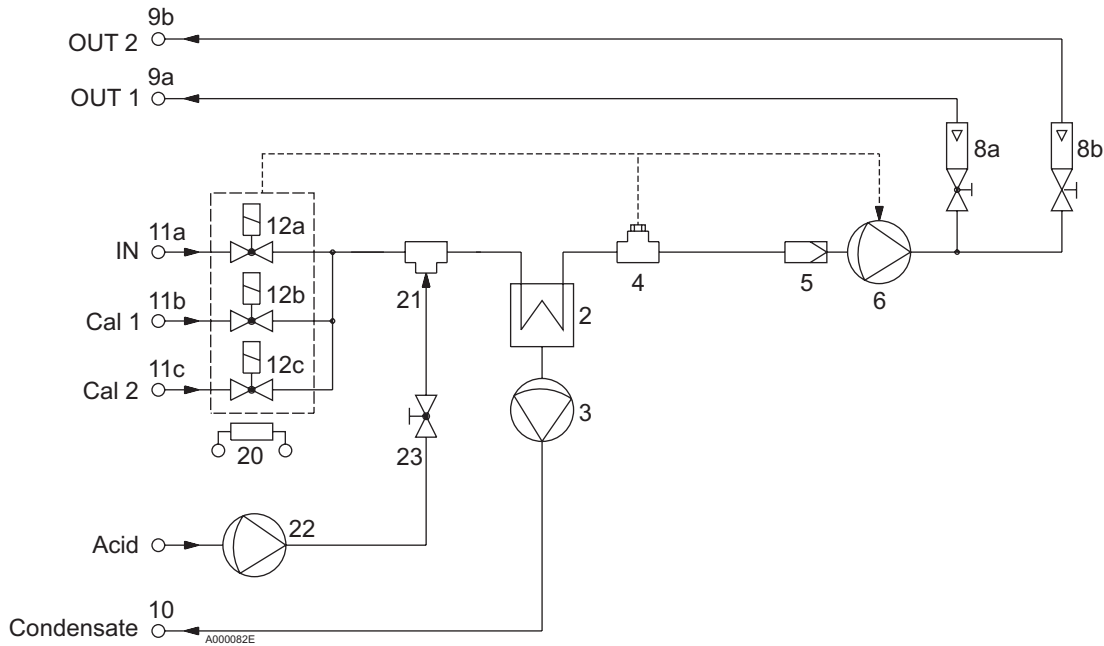

The sample gas is pumped through the heated valve block (12) and the sample gas cooler PKE 19 (2) by the gas pump (6). The moisture condenses inside the cooler's heat exchanger. The condensate pump (3) removes to the condensate outlet (10). Upstream of the cooler, acidification with phosphoric acid reduces the scrubbing of sulfur dioxide inside the heat exchanger (This is not a necessary option in every system). The acid is added by a pump (22) regulated by a valve (23).

The temperature of the cooling block is shown on a display on the front panel. A dewpoint alarm is provided in case the temperature deviates from the set-point by more than 3K. An LED display will flash and the gas pump will be immediately stopped to prevent damage to downstream devices.

A moisture detector (4) is added downstream of the cooler providing an alarm in case of moisture breakthrough. This will also shut down the gas pump (6). The alarm is displayed on the front panel.

The filter (5) on the front panel protects the downstream components and analyzer from being particulate contamination. The final components are the flow meters (8) including needle valves (two in this application).

Two calibration gases may be regulated by the magnetic valves (12a,b). These are located on the heated valve block together with the input valve (12a). The temperature is regulated by the SCS controller. A low temperature will stop the pump.

Gas wetted material used in this application are: stainless steel, Viton, glass, Novopren, and PVDF. The lines are Viton.

Manual control is accomplished by a simple rotary switch with the functions "external control", "measure", "calibration gas 1" and "calibration gas 2". The condensate pump can be switched off for easy maintenance of the pump hose.

All status and mode signals of the SCS are shown on the front panel and can be accessed on terminals on the back side. Another terminal is used to control the system mode from outside.

Technical Data for the 19" Sample Gas Conditioning System SCS

Possible cooler modules / No. of gas streams	PKE 19 / 1 stream	EGK 19 / 1 stream	EGK 19 / 2 stream
Gas paths			
Number of gas outs / calibration gases	Depending on application		
Gas covered materials standard ²⁾	Viton, PTFE, stainless steel, Novopren, PVDF, PP ²⁾		
Maximum pressure ³⁾	Depending on application and built-in parts		
Gas terminals (standard)	Hose fittings DN 4/6		
Standard flow rate free	300 l/h	550 l/h	2 x 300 l/h
With -150 mbar rel. at input and +120 mbar rel at output	150 l/h	350 l/h	2 x 150 l/h
Dead Volume approx. (dep. on application)	85 cm ³	100 cm ³	70 cm ³ each
Electrical data			
Electrical control contacts	Driven by dry contacts or common ground		
Electrical status and mode outputs max.	230 VAC / 150 VDC; 0.5 A; 50 VA, dry contacts		
Power supply	115 V / 60 Hz or 230 V / 50 Hz		
Power consumption (dep. on application)	200...350 VA	450...550 VA	500...600 VA
Gas cooler data			
Cooling power at 25°C (40°C) ¹⁾	70(30) kJ/h 66(28) Btu/h	360(100) kJ/h 340(95) Btu/h	360(100) kJ/h 340(95) Btu/h
Max. flow rate ¹⁾ (steel / glass)	300 l/h	400 l/h	2 x 200/125 l/h
Max. gas inlet temperature ¹⁾	180°C / 355°F	180°C / 355°F	180°C / 355°F
Max. inlet dew point (1 bar abs.) ¹⁾	65°C / 150°F	80°C / 175°F	80°C / 175°F
Ambient temperature ¹⁾	50°C / 120°F	50°C / 120°F	50°C / 120°F
Outlet dew point	Standard 5°C (41°F) factory pre-adjustable 3...15°C (37...60°F)		
Dew point stability static	0.2K	0.2K	0.2K
General data			
Dimensions	See table below		
Weight (depending on application)	15...20 kg 33...44 lb	15...20 kg 33...44 lb	25...30 kg 55...66 lb
Start-up time max.	15 min	15 min	15 min

Remarks:

- 1) The maximum values depend on: the ambient temperature and therefore the available cooling power. Our application specialists can help determine the appropriate cooling module for your application..
- 2) Appropriate materials are application specific.
- 3) The pressure values depend on the selected components. Internal tubing for higher pressures is an option.

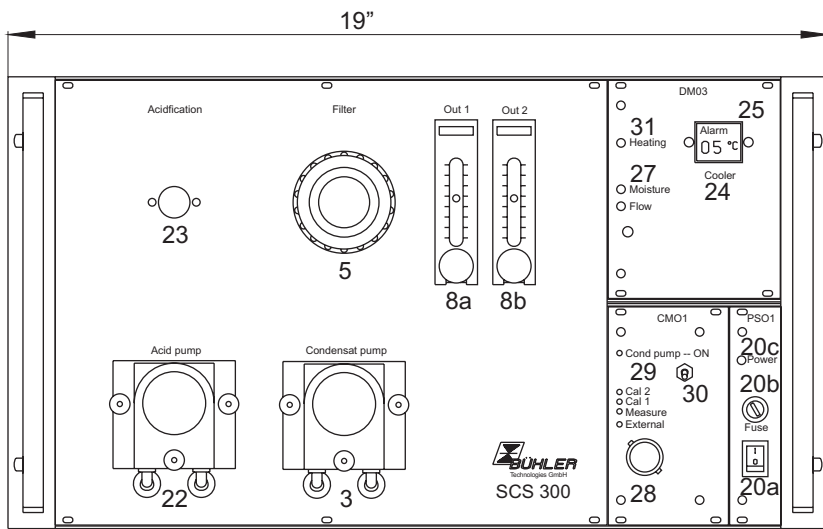

Explanations

- 3 Condensate pump
- 5 Filter
- 8a,b Flow meters for output
- 9a,b Gas out terminals
- 10 Condensate out terminal
- 11a Sample gas inlet
- 11b,c Calibration gas inlets
- 20a Main power switch
- 20b,c Main fuse and LED
- 22,23 Acid pump and valve
- 22a Acid inlet terminal
- 24,25 Cooler display and alarm LED
- 27 Moisture alarm LED
- 28 Rotary switch for mode selection
- 29 LEDs showing system mode
- 30 Switch for condensate pump
- 31 LED valve block temperature
- 40 Status output terminals
- 42 External control inputs
- 43 Power terminal

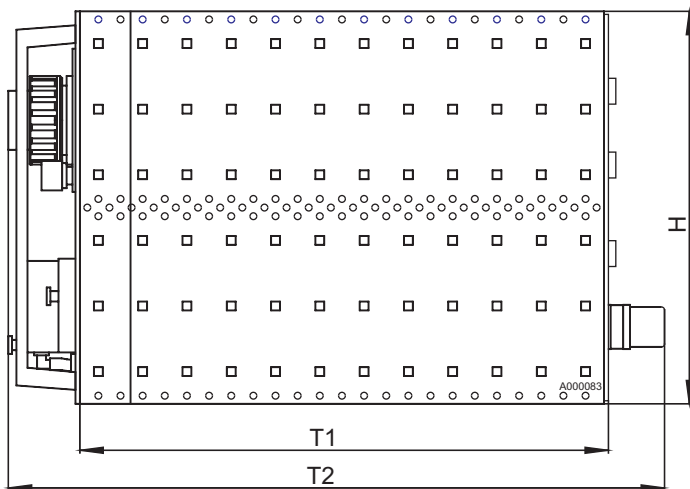
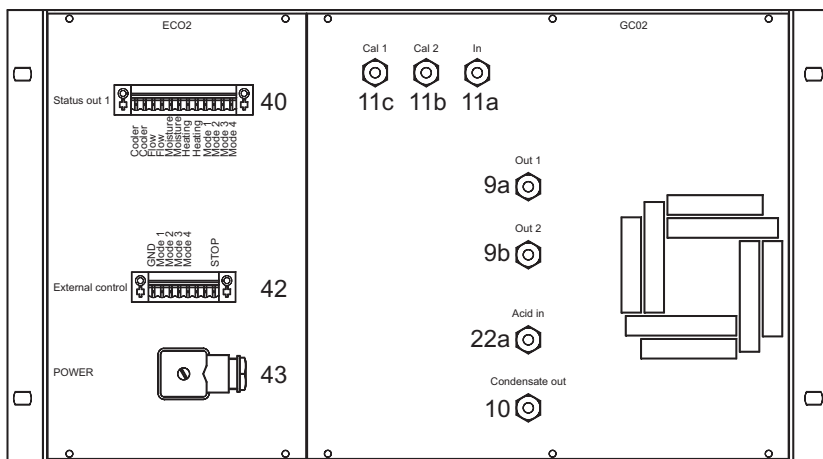

Dimensions

	with cooler type		
	PKE 19	EGK 19	2-stream
H	6 HU	6 HU	9 HU
T1	355 mm 14.98"	475 mm 18.70"	475 mm 18.70"
T2 appr.	420 mm 16.5"	540 mm 21.3"	540 mm 21.3"

Ordering hints

Please answer the attached questionnaire or contact one of our application specialists. Based on your specification, we will customize the modules and components.

For applications with 2 gas paths, please fill in one questionnaire for each path (unless identical). Please note that the possible extensions may be limited by the room given on the front panel.

Use the second page for explanations. Any specifications and drawings e.g. gas flow charts may also be attached

Spare parts recommended for maintenance

Filter elements: (according to built in filter): FE-E1 (5 pieces) Part no. 41 15 00 10
FE-4 Part no. 41 15 10 4

Hose for condensate pump or hose for acid pump

Part no. 9124 030027