



## Sample gas cooler

### Series EGK 1/2

# Installation and Operation Instructions

Original instructions





Bühler Technologies GmbH, Harkortstr. 29, D-40880 Ratingen  
Tel. +49 (0) 21 02 / 49 89-0, Fax: +49 (0) 21 02 / 49 89-20  
Internet: [www.buehler-technologies.com](http://www.buehler-technologies.com)  
E-Mail: [analyse@buehler-technologies.com](mailto:analyse@buehler-technologies.com)

Read this instruction carefully prior to installation and/or use. Pay attention particularly to all advises and safety instructions to prevent injuries. Bühler Technologies can not be held responsible for misusing the product or unreliable function due to unauthorised modifications.

All rights reserved. Bühler Technologies GmbH 2024

Document information

Document No..... BE450001  
Version..... 03/2024

# Contents

1	Introduction .....	2
1.1	Intended Use .....	2
1.2	Types .....	2
1.3	Scope of delivery .....	2
1.4	Ordering instructions .....	2
2	Safety instructions .....	3
2.1	Important advice .....	3
2.2	General hazard warnings .....	4
3	Transport and storage .....	5
4	Installation and connection .....	6
4.1	Installation site requirements .....	6
4.2	Installation .....	6
4.2.1	Peristaltic pump connector (optional) .....	6
4.2.2	Connecting the heat exchanger .....	7
4.3	Electrical connections .....	7
5	Operation and control .....	9
5.1	Use of menu functions .....	9
5.1.1	Overview of the menu items .....	10
5.1.2	Detailed description of the operational principle .....	10
5.2	Description of menu functions .....	11
5.2.1	Main menu .....	11
5.2.2	Submenu .....	11
6	Maintenance .....	12
7	Service and repair .....	13
7.1	Troubleshooting .....	13
7.2	Safety instructions .....	14
7.3	Cleaning and removal of the heat exchanger .....	15
7.4	Replacing the fuse of the cooler .....	15
7.5	Replacing the hoses of the peristaltic pump (option) .....	16
7.6	Spare parts .....	16
7.6.1	Consumables and accessories .....	16
8	Disposal .....	17
9	Appendices .....	18
9.1	Gas cooler technical data .....	18
9.2	Technical Data - Options .....	18
9.3	Performance data .....	19
9.4	Diagram typical installation .....	19
9.5	Heat exchanger .....	20
9.5.1	Heat exchanger description .....	20
9.5.2	Heat exchanger overview .....	20
9.6	Dimensions (mm) .....	21
10	Attached documents .....	22

# 1 Introduction

## 1.1 Intended Use

This unit is intended for industrial use in gas analysis systems. It's an essential component for conditioning the sample gas to protect the analysis instrument from residual moisture in the sample gas.

Please note the specifications in the data sheets on the specific intended use, existing material combinations, as well as pressure- and temperature limits.

## 1.2 Types

The device is delivered with different configurations. The part number given on the type plate informs you about the specific configuration of your device.

## 1.3 Scope of delivery

- Cooler
- Product documentation
- Connection-/mounting accessories (optional)

## 1.4 Ordering instructions

The item number is a code for the configuration of your unit. Please use the following model key:

**Please note:** Every individual gas path must be equipped with peristaltic pump or condensate drain.

4562	X	X	X	X	X	0	0	0	Product Characteristics
									<b>Voltage</b>
1									115 V metric screw connections
2									230 V metric screw connections
3									115 V US screw connections
4									230 V US screw connections
									<b>Gas path / Material / Version</b>
0	0	0							without heat exchanger
1	1	0							1 gas path / single stainless steel heat exchanger / (TS and TS-I)
1	2	0							1 gas path / single glass heat exchanger / (TG)
1	3	0							1 gas path / single PVDF heat exchanger / (TV and TV-I)
2	6	0							2 gas paths / dual stainless steel heat exchanger / (DTS and DTS-I)
2	6	1							2 gas paths / dual stainless steel heat exchanger / (DTS-6 and DTS-6-I) <sup>1)</sup>
2	7	0							2 gas paths / dual glass heat exchanger / (DTG)
2	8	0							2 gas paths / dual PVDF heat exchanger / (DTV and DTV-I) <sup>1)</sup>
									<b>Condensate drain</b> <sup>2)</sup>
	0								without condensate drain
	3								Peristaltic pump(s) CPsingle with hose connection 90° angle <sup>3)</sup>
	4								Peristaltic pump(s) CPsingle with screw-in hose connection <sup>3)</sup>

<sup>1)</sup> Condensate outlets only suitable for connecting peristaltic pumps.

<sup>2)</sup> Peristaltic pumps also available for separate installation, see data sheet 450020.

<sup>3)</sup> Each gas path equipped with a peristaltic pump. The supply voltage corresponds with that of the main unit.

## 2 Safety instructions

### 2.1 Important advice

Operation of the device is only permitted if:

- the product is used under the conditions described in the installation- and operation instruction, the intended application according to the type plate and the intended use. In case of unauthorized modifications done by the user Bühler Technologies GmbH can not be held responsible for any damage,
- when complying with the specifications and markings on the nameplates.
- the performance limits given in the datasheets and in the installation- and operation instruction are obeyed,
- monitoring devices and safety devices are installed properly,
- service and repair is carried out by Bühler Technologies GmbH,
- only original spare parts are used.

This manual is part of the equipment. The manufacturer keeps the right to modify specifications without advanced notice. Keep this manual for later use.

### Signal words for warnings

<b>DANGER</b>	Signal word for an imminent danger with high risk, resulting in severe injuries or death if not avoided.
<b>WARNING</b>	Signal word for a hazardous situation with medium risk, possibly resulting in severe injuries or death if not avoided.
<b>CAUTION</b>	Signal word for a hazardous situation with low risk, resulting in damaged to the device or the property or minor or medium injuries if not avoided.
<b>NOTICE</b>	Signal word for important information to the product.

### Warning signs

These instructions include the following warnings:

	General warning sign		General mandatory sign
	Voltage warning		Unplug from mains
	Warning not to inhale toxic gases		Wear respiratory equipment
	Warning of corrosive substances		Wear a safety mask
	Warning of explosion hazard		Wear gloves

## 2.2 General hazard warnings

The equipment must be installed by a professional familiar with the safety requirements and risks.

Be sure to observe the safety regulations and generally applicable rules of technology relevant for the installation site. Prevent malfunctions and avoid personal injuries and property damage.

### The operator of the system must ensure:

- Safety notices and operating instructions are available and observed,
- The respective national accident prevention regulations are observed,
- The permissible data and operational conditions are maintained,
- Safety guards are used and mandatory maintenance is performed,
- Legal regulations are observed during disposal,
- compliance with national installation regulations.
- the device is protected from mechanical loads.

### Maintenance, Repair

Please note during maintenance and repairs:

- Repairs to the unit must be performed by Bühler authorised personnel.
- Only perform conversion-, maintenance or installation work described in these operating and installation instructions.
- Always use genuine spare parts.
- Do not install damaged or defective spare part. If necessary, visually inspect prior to installation to determine any obvious damage to the spare parts.

Always observe the applicable safety and operating regulations in the respective country of use when performing any type of maintenance.

#### DANGER

#### Electrical voltage



Electrocution hazard.

- a) Disconnect the device from power supply.
- b) Make sure that the equipment cannot be reconnected to mains unintentionally.
- c) The device must be opened by trained staff only.
- d) Regard correct mains voltage.



#### DANGER

#### Toxic, corrosive gas/condensate



Sample gas/condensate may be hazardous to health.

- a) If necessary, ensure a safe gas/condensate discharge.
- b) Always disconnect the gas supply when performing maintenance or repairs.
- c) Protect yourself from toxic/corrosive gasses/condensate when performing maintenance. Wear appropriate protective equipment.



#### DANGER

#### Potentially explosive atmosphere



Explosion hazard if used in hazardous areas.

The device is not suitable for operation in hazardous areas with potentially explosive atmospheres.

Do not expose the device to combustible or explosive gas mixtures.

## 3 Transport and storage

Only transport the product inside the original packaging or a suitable alternative.

The equipment must be protected from moisture and heat when not in use. It must be stored in a covered, dry and dust-free room at a temperature of -20 °C to 60 °C (-4 °F to 140 °F).

## 4 Installation and connection

### 4.1 Installation site requirements

The unit is intended for wall-mounted or table-top use in enclosed areas. Adequate protection from the weather must be provided when used outdoors.

Install the unit leaving enough room below the cooler to discharge the condensate. Leave room above for the gas supply.

Be sure to maintain the approved ambient temperature. Do not obstruct the convection of the cooler. The vents must have enough room to the next obstacle. The distance must especially be a minimum of 10 cm on the air outlet side.

Ensure adequate ventilation when installing in enclosed housings, e.g. analyser cabinets. If the convection is inadequate, we recommend aerating the cabinet or installing a fan to lower the inside temperature.

### 4.2 Installation

Run the gas supply to the cooler with a downward slope. The gas inputs are marked in red and additionally labelled "IN".

If a large amount of condensate accumulates, we recommend using a condensate trap with automatic condensate drain. Our condensate drains, 11 LD spec., AK 20 V, or model 165 SS, are suitable.

Glass vessels and automatic condensate drains are available for draining condensate for external mounting below the unit. When using automatic condensate drains, the sample gas pump must be installed upstream of the cooler (pressure operation) to ensure proper function of the condensate drain.

If the sample gas pump is located at the cooler outlet (suction operation), we recommend using glass condensate traps or peristaltic pumps.

#### Connecting the condensate drains

Depending on the material, build a connecting line with fittings and tubing or hose between the heat exchanger and condensate drain. For stainless steel the condensate drain can be suspended directly to the connecting tube, for hoses the condensate drain must be secured separately using a clamp.

The condensate drain can be mounted directly to the heat exchanger.

Condensate lines must always be installed with a slope and a minimum inside diameter of DN 8/10 (5/16").

The DTV heat exchanger cannot be operated in conjunction with an automatic condensate drain.

#### 4.2.1 Peristaltic pump connector (optional)

Coolers ordered with built-in peristaltic pumps already have these installed and wired. Heat exchangers ordered at the same time are already installed and connected to the peristaltic pumps.

#### NOTICE



Installing peristaltic **pumps** CPsingle / CPdouble limits the maximum permissible **operating pressure** in the system!  
Operating pressure  $\leq 1$  bar

A peristaltic pump may also be installed away from the cooler. A mounting angle is available for mounting the pump directly below the cooler. Mounts for securing the angle directly to the cooler are designated.



## 4.2.2 Connecting the heat exchanger

The gas inputs are marked in red.

On glass heat exchangers the correct position of the seal is important when connecting the gas lines (see image). The seal consists of a silicone ring with a PTFE sleeve. The PTFE side must face the glass thread.

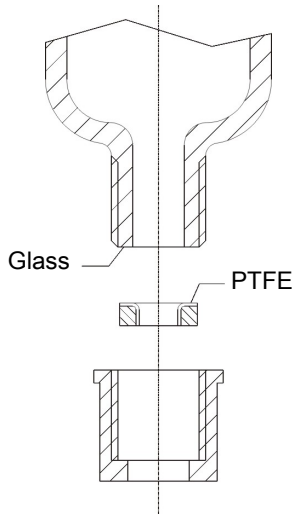

Pay attention to the appropriate spanner size when selecting fittings for stainless steel heat exchangers.

TS/TS-I gas connections: SW 17

TS/TS-I condensate out connections: SW 22

## 4.3 Electrical connections

The operator must install an external separator for the device which is clearly assigned to this device.

This separator

- must be located near the device,
- must be easy for the operator to reach,
- must comply with IEC 60947-1 and IEC 60947-3,
- must separate all live conductors and the status output, and
- must not be attached to the power feed.

### WARNING

#### Hazardous electrical voltage



The device must be installed by trained staff only.

### CAUTION

#### Wrong mains voltage



Wrong mains voltage may damage the device.  
Regard the correct mains voltage as given on the type plate.

### WARNING

#### High voltage



Damage to the device in case of insulation testing  
**Do not proceed insulation tests with high voltage** to the device as a whole!

### Insulation test

The device is equipped with extensive EMC protection. If insulation tests are carried out the electronic filter devices will be damaged. All necessary tests have been carried out for all concerned groups of components at the factory (test voltage 1 kV or 1.5 kV respectively, depending on the device).

If you wish to carry out the insulation test by yourself, please test only separate groups of components.

Disconnect the compressor, the fan, the heating or the peristaltic pumps, respectively, and then carry out the insulation tests.

### Plug connection

This device has one EN 175301-803 plug each for the power supply and the signal output. If the lead is connected correctly, these cannot be confused. Therefore please be sure to correctly reassemble the plugs after connecting the wires. Below you will find the pin assignments, with the numbers corresponding to those on the plugs:

The supply line cross-sections must be suitable for the rated current. Use a maximum line cross-section of 1.5 mm<sup>2</sup> (AWG 16) and a cable diameter of 8 - 10 mm (0.31 - 0.39 inch).

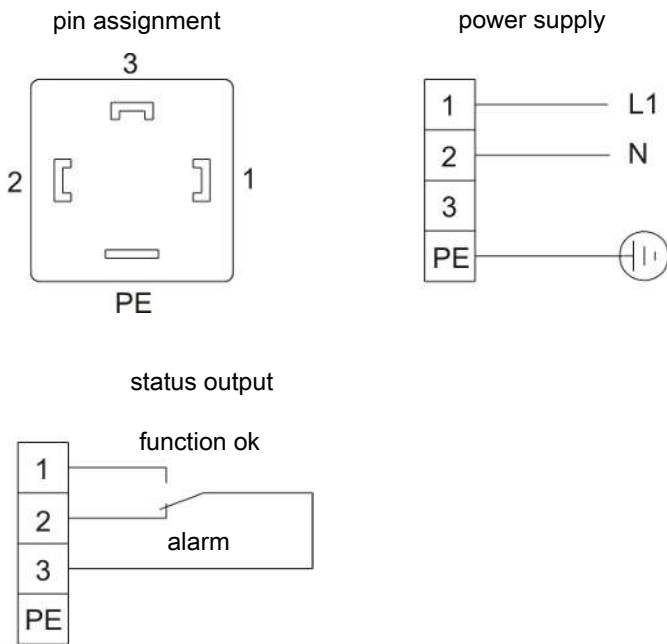

Fig. 1: A05-100002 Cooler electric supply

The mains supply must be protected with 10 A. The clamping area has a diameter of 8-10 mm.

## 5 Operation and control

### NOTICE



The device must not be operated beyond its specifications.

After switching on the cooler the block temperature will be displayed. The display will flash until the block temperature has reached the preset target value ( $\pm$  adjustable alarm range). The status contact is in the Alarm position.

Once the target temperature range has been reached, the temperature will continuously be displayed and the status contact switches over.

If the display flashes during operation or an error message appears, please refer to bullet "Troubleshooting".



Please refer to the data sheet for performance data and maximum ratings.

### 5.1 Use of menu functions

#### Overview of the operational principal:

Use this short description if you have experience with the device.

Operation is carried out by only the keys with the following functions:

Key	Function
	<ul style="list-style-type: none"> <li>– Switch from measurement display to main menu</li> <li>– Selection of the display menu item</li> <li>– Accepting the changed value or selection</li> </ul>
	<ul style="list-style-type: none"> <li>– Switch to the upper menu item</li> <li>– Increase of the value of switching the selection</li> <li>– Temporary display of the alternative measurement display (if option is installed)</li> </ul>
	<ul style="list-style-type: none"> <li>– Switch to lower menu item</li> <li>– Decrease of the value of switching the selection</li> <li>– Temporary display of the alternative measurement display (if option is installed)</li> </ul>

## 5.1.1 Overview of the menu items

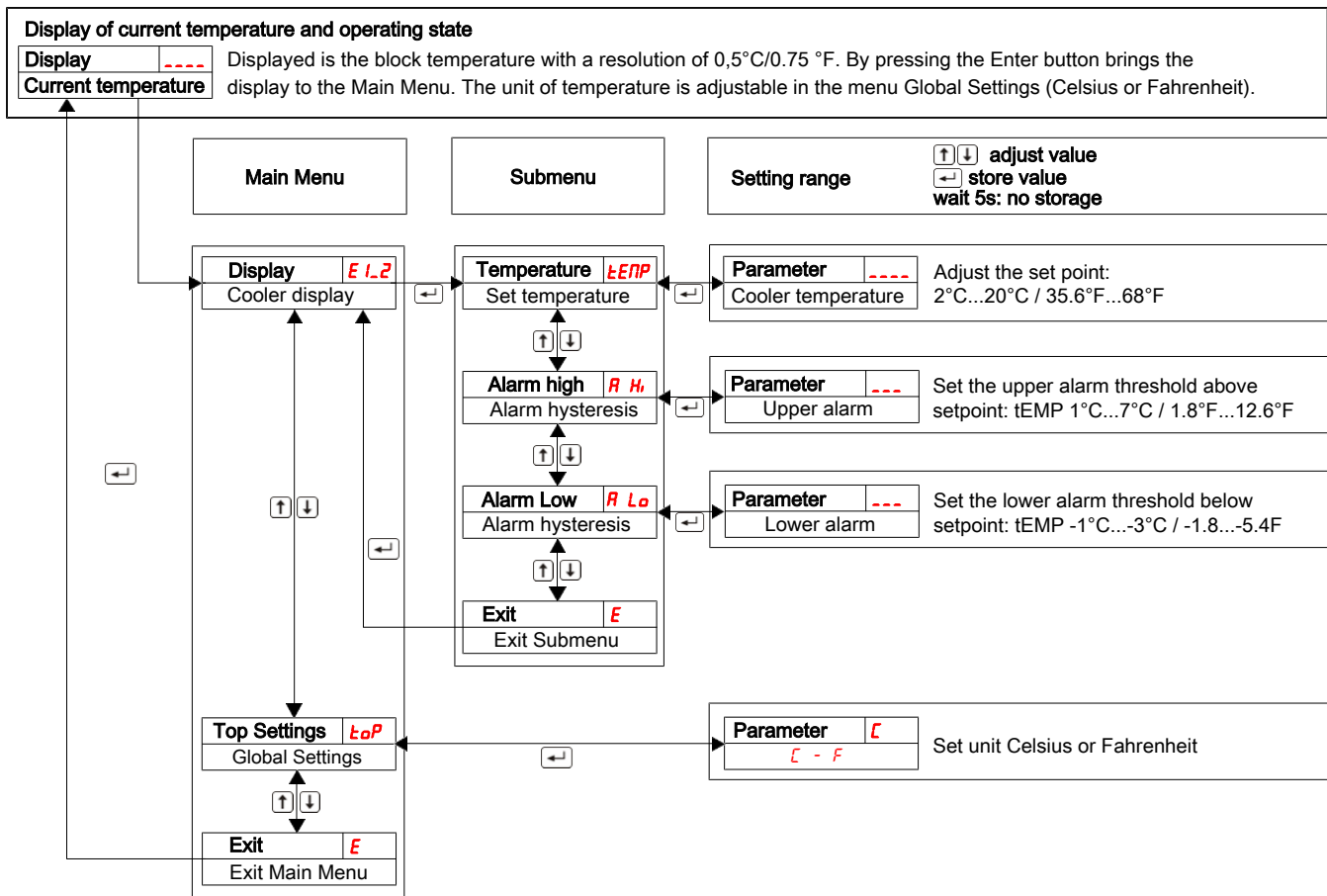

## 5.1.2 Detailed description of the operational principle

The detailed description will guide you through the menu step by step.

Connect the unit to the power supply and wait for the startup procedure to complete. At first the software version implemented on the unit will be displayed for a brief period. The unit will then switch directly into measured value display.

- ↵ Pressing the button will take you from display mode to the main menu. (The control will continue running whilst in menu mode.)
- ↑ ↓ Use these buttons to navigate the main menu.
- ↵ After confirming a main menu item the associated submenu will open

Here you can configure operating parameters:

- ↑ ↓ Cycle through the submenu to configure the parameters,
- ↵ then confirm the menu item to be changed.

- ↑ ↓ You can now set values within specific limits.

- ↵ After confirming the value the system will save it. This will automatically return you to the submenu.

If no button is pushed for approx. 5 s, the unit will automatically return to the submenu. Changes to values will not be saved.

The same applies to the sub- and main menu. The system will automatically return to display mode without saving the (last) value changed. Parameters which were previously changed and saved will be retained and not reset.

**NOTICE! After saving values with the Enter key they will be applied to the control.**

- E To exit the main or submenu, select menu item E (Exit).

## 5.2 Description of menu functions

### 5.2.1 Main menu

#### Cooler

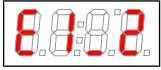

From here you will be able to access to all relevant cooler settings. The related submenu allows you to select the target temperature and alarm thresholds.

#### Globale settings (ToP Settings)



Selection of the global temperature unit, either degree Celsius (C) or degree Fahrenheit (F).

Note:

This menu item has no sub-item. The temperature unit is directly selected.

#### Exit main menu

Display → E

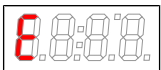

Selecting this will return you to display mode.

### 5.2.2 Submenu

#### Cooler -> nominal temperature (temperature)



This setting determines the nominal temperature for the cooler temperature. The value can be set to a range from 2 °C (35.6 °F) to 20 °C (68 °F).

Note:

The standard value at delivery is 5 °C (41 °F) (unless otherwise agreed). If the temperature is changed the indicator may blink, until the new operating range has been reached.

#### Cooler -> upper alarm limit (alarm high)



Here you can set the upper threshold for the visual signal and the alarm relay. The alarm limit is set to a range from 1 °C (1.8 °F) to 7 °C (12.6 °F) in relation to the cooler temperature setting.

Note:

The standard value at delivery is 3 °C (5.4 °F) (unless otherwise agreed).

#### Cooler -> lower alarm limit (alarm low)



Here you can set the lower threshold for the visual signal and the alarm relay. The alarm limit is set to a range from -1 °C (-1.8 °F) to -3 °C (-5.4 °F) in relation to the cooler temperature setting.

Note:

The standard value at delivery is -3 °C (-5.4 °F) (unless otherwise agreed).

#### Exit submenu



Selecting this item returns to the main menu.

## 6 Maintenance

The basic version of the cooler requires no special maintenance.

However, it may have different options depending on the cooler model. In this case the following maintenance must be performed regularly:

- **Optional peristaltic pump:** Check hoses

During maintenance, remember:

- The equipment must be maintained by a professional familiar with the safety requirements and risks.
- Only perform maintenance work described in these operating and installation instructions.
- Observe the respective safety regulations and operating specifications when performing any type of maintenance.
- Always use genuine spare parts.

### DANGER

#### Electrical voltage

Electrocution hazard.



- Disconnect the device from power supply.
- Make sure that the equipment cannot be reconnected to mains unintentionally.
- The device must be opened by trained staff only.
- Regard correct mains voltage.



### DANGER

#### Toxic, corrosive gas/condensate

Sample gas/condensate may be hazardous to health.



- If necessary, ensure a safe gas/condensate discharge.
- Always disconnect the gas supply when performing maintenance or repairs.
- Protect yourself from toxic/corrosive gasses/condensate when performing maintenance. Wear appropriate protective equipment.



## 7 Service and repair

This chapter contains information on troubleshooting and correction should an error occur during operation.

Repairs to the unit must be performed by Bühler authorised personnel.

Please contact our Service Department with any questions:

**Tel.: +49-(0)2102-498955** or your agent

For further information about our services and customised maintenance visit <http://www.buehler-technologies.com/service>.

If the equipment is not functioning properly after correcting any malfunctions and switching on the power, it must be inspected by the manufacturer. Please send the equipment inside suitable packaging to:

**Bühler Technologies GmbH**

**- Reparatur/Service -**

**Harkortstraße 29**

**40880 Ratingen**

**Germany**

Please also attach the completed and signed RMA decontamination statement to the packaging. We will otherwise be unable to process your repair order.

You will find the form in the appendix of these instructions, or simply request it by e-mail:

**service@buehler-technologies.com.**

### 7.1 Troubleshooting

Problem / Malfunction	Possible cause	Action
No display	– Mains voltage interrupted	– Connect to mains; verify – the plug is inserted correctly
	– Fuse defective	– Check fuse and replace, if necessary
Cooler doesn't start up	– Compressor housing temperature too high	– Allow to cool down and ensure adequate ventilation
Display flashes due to:		
– Excess temperature	– Operating point not yet reached	– Wait (max. 20 min)
	– Cooling output too low despite the cooler running	– Ensure the vents are not covered (heat buildup)
	– Flow rate / dew point / gas temperature too high	– Maintain limits / install pre-separator
	– Built-in fan stopped	– Check and replace if necessary
– Temperature low	– Control unit failure	– Send in cooler
Condensate inside the gas output	– Condensate trap full	– Empty condensate trap
	– Valve inside the automatic condensate drain may be stuck	– Flush in both directions
	– Cooler overload	– Maintain limits
Reduced gas flow rate	– Gas circuit clogged	– Remove and clean heat exchanger
	– Condensate output iced over	– Send in cooler
No cooling	– Compressor doesn't start up	– Compressor PTC not cooled down sufficiently. Wait 5 minutes and try again.
Fuse is triggering	– Increased compressor current consumption due to faulty compressor start-up	– Compressor PTC not cooled down sufficiently. Wait 5 minutes and try again.

## Error Messages in the Display

The display alternates between the temperature and error message,

Problem / Malfunction	Possible cause	Action
 Error 01	– Interruption	– Temperature sensor failure: Send in cooler
 Error 02	– Short circuit	– Temperature sensor failure: Send in cooler

## 7.2 Safety instructions

- The device must be operated within its specifications.
- All repairs must be carried out by Bühler authorised personnel only.
- Only perform modifications, servicing or mounting described in this manual.
- Only use original spare parts.

### DANGER

#### Electrical voltage



Electrocution hazard.

- Disconnect the device from power supply.
- Make sure that the equipment cannot be reconnected to mains unintentionally.
- The device must be opened by trained staff only.
- Regard correct mains voltage.



### DANGER

#### Toxic, corrosive gas/condensate



Sample gas/condensate may be hazardous to health.

- If necessary, ensure a safe gas/condensate discharge.
- Always disconnect the gas supply when performing maintenance or repairs.
- Protect yourself from toxic/corrosive gasses/condensate when performing maintenance. Wear appropriate protective equipment.



### CAUTION

#### Health hazard in case of leaking cooling circuit / heat exchanger



The cooling circuit is filled with coolant R134a.

The heat exchanger is filled with a coolant based on glycol.

In case of leaking / broken cooling circuit / heat exchanger:

- Avoid contact with skin or eyes.
- Do not ingest or inhale coolant.
  - ⇒ Due to the small amount of coolant no health hazards need be feared.
  - ⇒ Do not put the device back to operation if leakage of the cooling circuit happend.



## 7.3 Cleaning and removal of the heat exchanger

Heat exchangers only need to be replaced or maintained if clogged or damaged. If they are clogged, we recommend checking if using a filter will avoid future occurrences.

- Close gas supply.
- Switch off device and disconnect all plugs (e.g. status output connector, supply input, etc.).
- Disconnect gas connections and condensate drain.
- Pull the heat exchanger up and out.
- Clean cleaning nest (hole inside the cooler block), as the heat exchangers are installed with silicone grease.
- Flush the heat exchanger until all contaminants have been removed.
- Grease the cooled outside surface external surface with silicone grease.
- Reinsert the heat exchanger into the cooling nest with a rotating movement.
- Reconnect the gas supply and condensate drain. The gas inlet is marked red.
- Restore power/gas supply and wait for unit to be ready for operation.
- Open gas supply.

## 7.4 Replacing the fuse of the cooler

- Close the gas supply.
- Switch off and unplug the device.
- If applicable, disconnect the tubing between the condensate drain and peristaltic pumps, and the heat exchanger and filters.
- Loosen the screws on the cover.
- Carefully remove the cover. **CAUTION! The display is attached to the front face and connected to the electronics on the base plate. The plug connection can be removed. Pumps, filters and moisture detector are connected to the electronics. The connections cannot be disconnected.**
- The fuse is located on the board under a plastic cap. Replace micro-fuse and put the cap back on. Please note the mains voltage in order to select the correct micro-fuse.
- Reconnect the plug connections and reattach the cover. Attach the mounting screws, or reinstall the pumps.
- Restore the power and gas supply.

### Example:



## 7.5 Replacing the hoses of the peristaltic pump (option)

- Turn off gas supply.
- Switch the device off and disconnect power supply.
- Remove the supplying and draining hoses from the pump (**Take care of the safety instructions!**).
- Loosen the centre knurled screw but do not remove it. Push the screw downwards.
- Pull off the cover.
- Pull the connections sideways and remove the hose.
- Replace the hose and remount the pump in reverse order.
- Reconnect power supply.

## 7.6 Spare parts

Please also specify the model and serial number when ordering parts.

Upgrade and expansion parts can be found in our catalog.

Available spare parts:

Item no.	Description
9100110124	Display ABT 400
9100010125	Controller board MCP 1
9100010133	Mains and controller board 230 V
9100010134	Mains and controller board 115 V
9110000001	Sample gas cooler micro-fuse, 5 x 20 mm, 800 mA, delayed action
4410030	Fan 230 V
4400030	Fan 115 V
4510130	Auxiliary angle with peristaltic pump "FM", 230 V AC 50/60Hz
4510131	Auxiliary angle with peristaltic pump "FM", 115 V AC 50/60Hz
4510230	Auxiliary angle with two peristaltic pumps "FM", 230 V AC 50/60Hz
4510231	Auxiliary angle with two peristaltic pumps "FM", 115 V AC 50/60Hz
4510140	Auxiliary angle with one peristaltic pump CPsingle, 115 / 230 V AC 50/60Hz
4510240	Auxiliary angle with two peristaltic pumps CPsingle, 115 / 230 V AC 50/60Hz
44920035011	Condensate pump hose, Tygon (Norpren), straight hose nipple
44920035012	Condensate pump hose, Tygon (Norpren), angled hose nipple
44920035013	Condensate pump hose, Tygon (Norpren), straight and angled hose nipple
44920035016	Condensate pump hose, Tygon (Norpren), angled hose nipple and screw connection (metric)
44920035017	Condensate pump hose, Tygon (Norpren), angled hose nipple and screw connection (US)

### 7.6.1 Consumables and accessories

Item no.	Description
4410001	Automatic condensate drain 11 LD V 38
4410004	Automatic condensate drain AK 20, PVDF
4410005	Condensate trap GL 1; glass, 0.4 L
4410019	Condensate trap GL 2; glass, 1 L
44921220102	CPsingle peristaltic condensate pump with angled hose nipple
44921220104	CPsingle peristaltic condensate pump with screw-in hose connection (metric)
44921220105	CPsingle peristaltic condensate pump with screw-in hose connection (US)

## 8 Disposal

The refrigerant circuit of the cooler contains R134a refrigerant. The heat exchanger is charged with glycol-based coolant.

The applicable national laws must be observed when disposing of the products. Disposal must not result in a danger to health and environment.

The crossed out wheelee bin symbol on Bühler Technologies GmbH electrical and electronic products indicates special disposal notices within the European Union (EU).



The crossed out wheelee bin symbol indicates the electric and electronic products bearing the symbol must be disposed of separate from household waste. They must be properly disposed of as waste electrical and electronic equipment.

Bühler Technologies GmbH will gladly dispose of your device bearing this mark. Please send your device to the address below for this purpose.

We are obligated by law to protect our employees from hazards posed by contaminated devices. Therefore please understand that we can only dispose of your waste equipment if the device is free from any aggressive, corrosive or other operating fluids dangerous to health or environment. **Please complete the "RMA Form and Decontamination Statement", available on our website, for every waste electrical and electronic equipment. The form must be applied to the packaging so it is visible from the outside.**

Please return waste electrical and electronic equipment to the following address:

Bühler Technologies GmbH  
WEEE  
Harkortstr. 29  
40880 Ratingen  
Germany

Please also observe data protection regulations and remember you are personally responsible for the returned waste equipment not bearing any personal data. Therefore please be sure to delete your personal data before returning your waste equipment.

## 9 Appendices

### 9.1 Gas cooler technical data

#### Gas Cooler Technical Data

Ready for operation	after max. 15 minutes		
Rated cooling capacity (at 25 °C)	320 kJ/h		
Ambient temperature	5 °C to 50 °C		
Gas outlet dew point, preset	approx. 5 °C		
Dew point fluctuations			
static:	± 0.1 K		
in the entire specification range:	± 1.5 K		
IP rating	IP 20		
Housing	Stainless steel		
Packaging dimensions	approx. 390 x 300 x 400 mm		
Weight incl. heat exchanger	approx. 15 kg		
Electric supply	115 V, 60 Hz or 230 V, 50 Hz Plug per EN 175301-803		
Electrical data		230 V	115 V
	Typical power input:	140 VA	155 VA
	max. operating current:	1.6 A	3.2 A
Alarm output switching connection	max. 250 V, 2 A, 50 VA Terminal plug per DIN 43650		
Installation	stand-alone or wall-mounted		

### 9.2 Technical Data - Options

#### CPsingle Peristaltic Pumps Technical Data

Flow rate	0.3 L/h (50 Hz) / 0.36 L/h (60 Hz) with standard hose
Vacuum inlet	max. 0.8 bar
Pressure inlet	max. 1 bar
Outlet pressure	1 bar
Hose	4 x 1.6 mm
Protection class	IP 40
Materials	
Hose:	Norprene (standard), Marprene, Fluran
Connections:	PVDF

### 9.3 Performance data

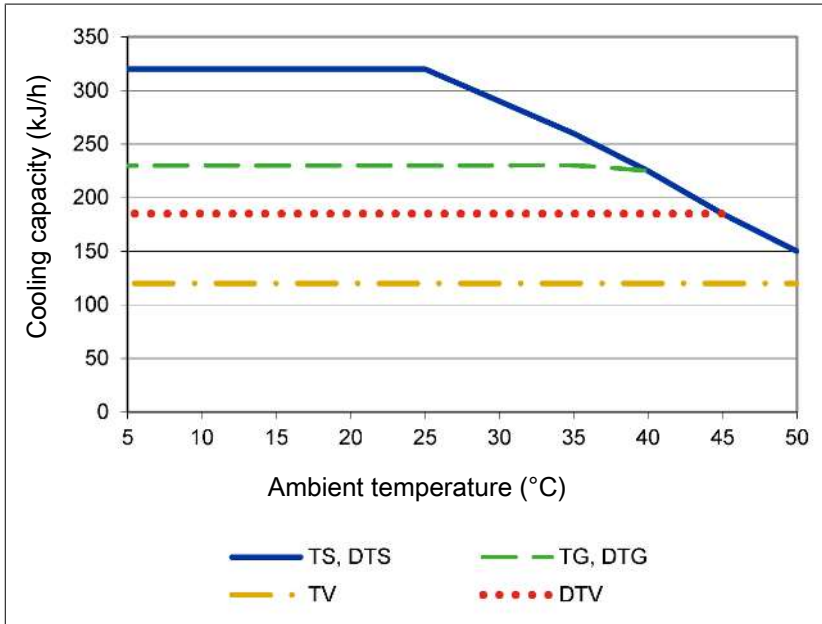

Remark: The limit curves for the heat exchangers exchanger apply to a dew point of 65 °C.

### 9.4 Diagram typical installation

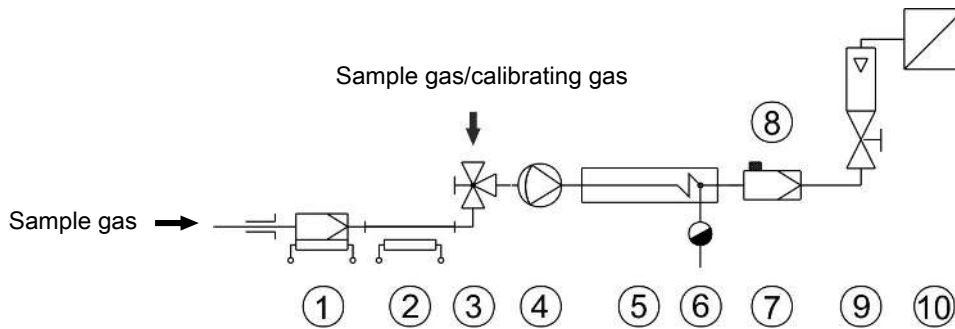

1 Sample gas probe	2 Sample gas line
3 Reversing tap	4 Sample gas pump
5 Sample gas cooler	6 Automatic condensate drain or peristaltic pump
7 Fine mesh filter	8 Moisture detector
9 Flow meter	10 Analyser

See data sheets for individual component models and data.

## 9.5 Heat exchanger

### 9.5.1 Heat exchanger description

The energy content of the sample gas and the required cooling capacity of the gas cooler is determined by three parameters: gas temperature  $\vartheta_G$ , (inlet) dew point  $\tau_e$  (moisture content) and volume flow  $v$ . The outlet dew point rises with increasing energy content of the gas. The approved energy load from the gas is therefore determined by the tolerated rise in the dew point.

The following limits are specified for a normal standard operating point of  $\tau_e = 65^\circ\text{C}$  and  $\vartheta_G = 90^\circ\text{C}$ . The maximum volume flow  $v_{\max}$  in NI/h of cooled air is indicated, so after moisture has condensed.

If the values fall below  $\tau_e$  and  $\vartheta_G$ , the flow  $v_{\max}$  may be increased. For example, on the TG heat exchanger the parameter triple  $\tau_e = 65^\circ\text{C}$ ,  $\vartheta_G = 90^\circ\text{C}$  and  $v = 280$  NI/h may also be used in place of  $\tau_e = 50^\circ\text{C}$ ,  $\vartheta_G = 80^\circ\text{C}$  and  $v = 380$  NI/h

Please contact our experts for clarification or refer to our design program.

### 9.5.2 Heat exchanger overview

Heat exchanger	TS TS-I <sup>2)</sup>	TG TG	TV TV-I <sup>2)</sup>	DTS (DTS-6 <sup>3)</sup> ) DTS-I (DTS-6-I <sup>3)</sup> ) <sup>2)</sup>	DTG DTG	DTV <sup>3)</sup> DTV-I <sup>2) 3)</sup>
Materials in contact with media	Stainless steel	Glass PTFE	PVDF	Stainless steel	Glass PTFE	PVDF
Flow rate $v_{\max}$ <sup>1)</sup>	530 L/h	280 L/h	155 L/h	2 x 250 L/h	2 x 140 L/h	2 x 115 L/h
Inlet dew point $\tau_{e,\max}$ <sup>1)</sup>	80 °C	80 °C	65 °C	80 °C	65 °C	65 °C
Gas inlet temperature $\vartheta_{G,\max}$ <sup>1)</sup>	180 °C	140 °C	140 °C	180 °C	140 °C	140 °C
Max. Cooling capacity $Q_{\max}$	450 kJ/h	230 kJ/h	120 kJ/h	450 kJ/h	230 kJ/h	185 kJ/h
Gas pressure $p_{\max}$	160 bar	3 bar	3 bar	25 bar	3 bar	2 bar
Pressure drop $\Delta p$ ( $v=150$ L/h)	8 mbar	8 mbar	8 mbar	5 mbar each	5 mbar each	15 mbar each
Dead volume $V_{\text{tot}}$	69 ml	48 ml	129 ml	28 / 25 ml	28 / 25 ml	21 / 21 ml
Gas connections (metric)	G1/4	GL 14 (6 mm) <sup>4)</sup>	DN 4/6	6 mm tube	GL14 (6 mm) <sup>4)</sup>	DN 4/6
Gas connections (US)	NPT 1/4"	GL 14 (1/4") <sup>4)</sup>	1/4"-1/6"	1/4" tube	GL14 (1/4") <sup>4)</sup>	1/4"-1/6"
Condensate out connections (metric)	G3/8	GL 25 (12 mm) <sup>4)</sup>	G3/8	Tube 10 mm (6 mm)	GL18 (10 mm) <sup>4)</sup>	DN 5/8
Condensate out connections (US)	NPT 3/8"	GL 25 (1/2") <sup>4)</sup>	NPT 3/8"	Tube 3/8" (1/4")	GL18 (3/8") <sup>4)</sup>	3/16"-5/16"

<sup>1)</sup> Max. cooling capacity of the cooler must be considered

<sup>2)</sup> Models marked I have NPT threads or US tubes, respectively.

<sup>3)</sup> Condensate drain only possible with condensate pump

<sup>4)</sup> Gasket inside diameter

### 9.6 Dimensions (mm)

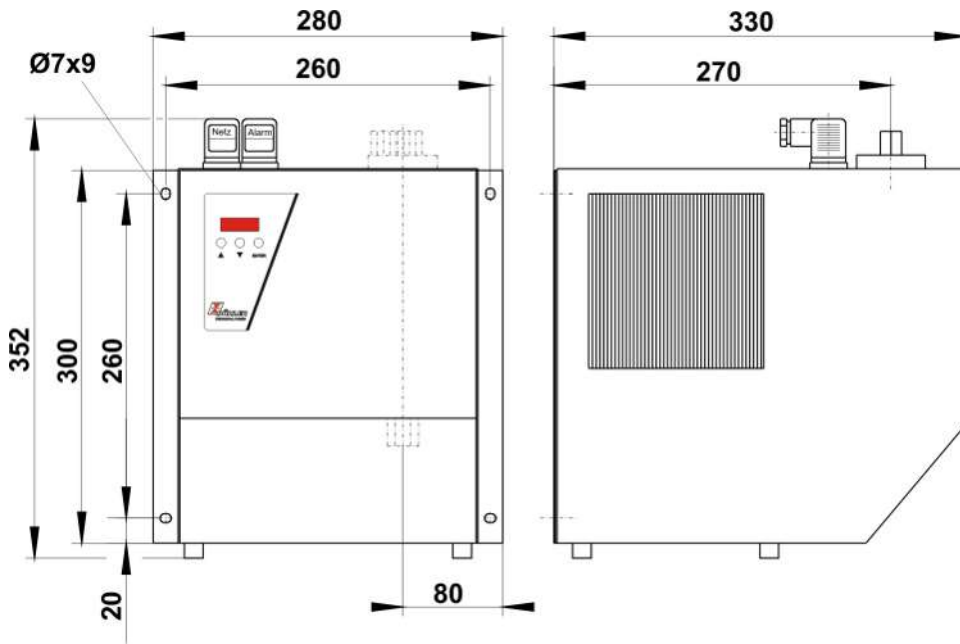

## 10 Attached documents

- Declaration of conformity KX450001
- RMA - Decontamination Statement



**EU-Konformitätserklärung**  
**EU-declaration of conformity**



Hiermit erklärt Bühler Technologies GmbH,  
dass die nachfolgenden Produkte den  
wesentlichen Anforderungen der Richtlinie

*Herewith declares Bühler Technologies GmbH  
that the following products correspond to the  
essential requirements of Directive*

**2014/35/EU**  
**(Niederspannungsrichtlinie / low voltage directive)**

in ihrer aktuellen Fassung entsprechen.

*in its actual version.*

Folgende Richtlinie wurde berücksichtigt:

*The following directive was regarded:*

**2014/30/EU (EMV/EMC)**

**Produkt / products:** Kompressor-Messgaskühler / *Compressor sample gas cooler*  
**Typ / type:** EGK 1, EGK 1 SD-L, EGK 1/2, EGK 1/2-L, EGK 4S, EGK 10

Das Betriebsmittel dient der Aufbereitung des Messgases, um das Analysengerät vor Restfeuchtigkeit  
im Messgas zu schützen.

*This equipment is used for conditioning the sample gas to protect the analysis instrument from residual  
moisture in the sample gas.*

Das oben beschriebene Produkt der Erklärung erfüllt die einschlägigen  
Harmonisierungsrechtsvorschriften der Union:

*The object of the declaration described above is in conformity with the relevant Union harmonisation  
legislation:*

**EN 61326-1:2013**

**EN 61010-1:2010/A1:2019/AC:2019-04**

Die alleinige Verantwortung für die Ausstellung dieser Konformitätserklärung trägt der Hersteller.  
*This declaration of conformity is issued under the sole responsibility of the manufacturer.*

Dokumentationsverantwortlicher für diese Konformitätserklärung ist Herr Stefan Eschweiler mit  
Anschrift am Firmensitz.

*The person authorized to compile the technical file is Mr. Stefan Eschweiler located at the company's  
address.*

Ratingen, den 17.02.2023

Stefan Eschweiler  
Geschäftsführer – *Managing Director*

Frank Pospiech  
Geschäftsführer – *Managing Director*

## UK Declaration of Conformity



The manufacturer Bühler Technologies GmbH declares, under the sole responsibility, that the product complies with the requirements of the following UK legislation:

### Electrical Equipment Safety Regulations 2016

The following legislation were regarded:

### Electromagnetic Compatibility Regulations 2016

**Product:** Compressor sample gas cooler  
**Types:** EGK 1  
EGK 1 SD-L  
EGK 1/2  
EGK 1/2-L  
EGK 4S  
EGK 10

The equipment is used for conditioning the sample gas to protect the analysis instrument from residual moisture in the sample gas.

The object of the declaration described above is in conformity with the relevant designated standards:

**EN 61010-1:2010/A1:2019/AC:2019-04**

**EN 61326-1:2013**

Ratingen in Germany, 17.02.2023

A handwritten signature in blue ink, appearing to read 'Stefan Eschweiler'.

Stefan Eschweiler  
Managing Director

A handwritten signature in blue ink, appearing to read 'Frank Pospiech'.

Frank Pospiech  
Managing Director

# RMA-Formular und Erklärung über Dekontaminierung

## RMA-Form and explanation for decontamination



RMA-Nr./ RMA-No.

Die RMA-Nr. bekommen Sie von Ihrem Ansprechpartner im Vertrieb oder Service. Bei Rücksendung eines Altgeräts zur Entsorgung tragen Sie bitte in das Feld der RMA-Nr. "WEEE" ein./ You may obtain the RMA number from your sales or service representative. When returning an old appliance for disposal, please enter "WEEE" in the RMA number box.

Zu diesem Rücksendeschein gehört eine Dekontaminierungserklärung. Die gesetzlichen Vorschriften schreiben vor, dass Sie uns diese Dekontaminierungserklärung ausgefüllt und unterschrieben zurücksenden müssen. Bitte füllen Sie auch diese im Sinne der Gesundheit unserer Mitarbeiter vollständig aus./ This return form includes a decontamination statement. The law requires you to submit this completed and signed decontamination statement to us. Please complete the entire form, also in the interest of our employee health.

### Firma/ Company

Firma/ Company

Straße/ Street

PLZ, Ort/ Zip, City

Land/ Country

Gerät/ Device

Anzahl/ Quantity

Auftragsnr./ Order No.

### Ansprechpartner/ Person in charge

Name/ Name

Abt./ Dept.

Tel./ Phone

E-Mail

Serien-Nr./ Serial No.

Artikel-Nr./ Item No.

### Grund der Rücksendung/ Reason for return

- Kalibrierung/ Calibration       Modifikation/ Modification  
 Reklamation/ Claim             Reparatur/ Repair  
 Elektroaltgerät/ Waste Electrical & Electronic Equipment (WEEE)  
 andere/ other

bitte spezifizieren/ please specify

### Ist das Gerät möglicherweise kontaminiert?/ Could the equipment be contaminated?

- Nein, da das Gerät nicht mit gesundheitsgefährdenden Stoffen betrieben wurde./ No, because the device was not operated with hazardous substances.  
 Nein, da das Gerät ordnungsgemäß gereinigt und dekontaminiert wurde./ No, because the device has been properly cleaned and decontaminated.  
 Ja, kontaminiert mit:/ Yes, contaminated with:



explosiv/  
explosive



entzündlich/  
flammable



brandfördernd/  
oxidizing



komprimierte  
Gase/  
compressed  
gases



ätzend/  
caustic



giftig,  
Lebensgefahr/  
poisonous, risk  
of death



gesundheitsge-  
fährdend/  
harmful to  
health



gesund-  
heitsschädlich/  
health hazard



umweltge-  
fährdend/  
environmental  
hazard

### Bitte Sicherheitsdatenblatt beilegen!/ Please enclose safety data sheet!

Das Gerät wurde gespült mit:/ The equipment was purged with:

*Diese Erklärung wurde korrekt und vollständig ausgefüllt und von einer dazu befugten Person unterschrieben. Der Versand der (dekontaminierten) Geräte und Komponenten erfolgt gemäß den gesetzlichen Bestimmungen.*

*This declaration has been filled out correctly and completely, and signed by an authorized person. The dispatch of the (decontaminated) devices and components takes place according to the legal regulations.*

Falls die Ware nicht gereinigt, also kontaminiert bei uns eintrifft, muss die Firma Bühler sich vorbehalten, diese durch einen externen Dienstleister reinigen zu lassen und Ihnen dies in Rechnung zu stellen.

Should the goods not arrive clean, but contaminated, Bühler reserves the right, to commission an external service provider to clean the goods and invoice it to your account.

Firmenstempel/ Company Sign

Datum/ Date

rechtsverbindliche Unterschrift/ Legally binding signature



### Vermeiden von Veränderung und Beschädigung der einzusendenden Baugruppe

Die Analyse defekter Baugruppen ist ein wesentlicher Bestandteil der Qualitätssicherung der Firma Bühler Technologies GmbH. Um eine aussagekräftige Analyse zu gewährleisten muss die Ware möglichst unverändert untersucht werden. Es dürfen keine Veränderungen oder weitere Beschädigungen auftreten, die Ursachen verdecken oder eine Analyse unmöglich machen.

### Umgang mit elektrostatisch sensiblen Baugruppen

Bei elektronischen Baugruppen kann es sich um elektrostatisch sensible Baugruppen handeln. Es ist darauf zu achten, diese Baugruppen ESD-gerecht zu behandeln. Nach Möglichkeit sollten die Baugruppen an einem ESD-gerechten Arbeitsplatz getauscht werden. Ist dies nicht möglich sollten ESD-gerechte Maßnahmen beim Austausch getroffen werden. Der Transport darf nur in ESD-gerechten Behältnissen durchgeführt werden. Die Verpackung der Baugruppen muss ESD-konform sein. Verwenden Sie nach Möglichkeit die Verpackung des Ersatzteils oder wählen Sie selber eine ESD-gerechte Verpackung.

### Einbau von Ersatzteilen

Beachten Sie beim Einbau des Ersatzteils die gleichen Vorgaben wie oben beschrieben. Achten Sie auf die ordnungsgemäße Montage des Bauteils und aller Komponenten. Versetzen Sie vor der Inbetriebnahme die Verkabelung wieder in den ursprünglichen Zustand. Fragen Sie im Zweifel beim Hersteller nach weiteren Informationen.

### Einsenden von Elektroaltgeräten zur Entsorgung

Wollen Sie ein von Bühler Technologies GmbH stammendes Elektroprodukt zur fachgerechten Entsorgung einsenden, dann tragen Sie bitte in das Feld der RMA-Nr. „WEEE“ ein. Legen Sie dem Altgerät die vollständig ausgefüllte Dekontaminierungserklärung für den Transport von außen sichtbar bei. Weitere Informationen zur Entsorgung von Elektroaltgeräten finden Sie auf der Webseite unseres Unternehmens.

### Avoiding alterations and damage to the components to be returned

Analysing defective assemblies is an essential part of quality assurance at Bühler Technologies GmbH. To ensure conclusive analysis the goods must be inspected unaltered, if possible. Modifications or other damages which may hide the cause or render it impossible to analyse are prohibited.

### Handling electrostatically conductive components

Electronic assemblies may be sensitive to static electricity. Be sure to handle these assemblies in an ESD-safe manner. Where possible, the assemblies should be replaced in an ESD-safe location. If unable to do so, take ESD-safe precautions when replacing these. Must be transported in ESD-safe containers. The packaging of the assemblies must be ESD-safe. If possible, use the packaging of the spare part or use ESD-safe packaging.

### Fitting of spare parts

Observe the above specifications when installing the spare part. Ensure the part and all components are properly installed. Return the cables to the original state before putting into service. When in doubt, contact the manufacturer for additional information.

### Returning old electrical appliances for disposal

If you wish to return an electrical product from Bühler Technologies GmbH for proper disposal, please enter "WEEE" in the RMA number box. Please attach the fully completed decontamination declaration form for transport to the old appliance so that it is visible from the outside. You can find more information on the disposal of old electrical appliances on our company's website.

