



## Gas cooler series TC-Kit

In the chemical industry, petrochemistry or biochemistry, reliable process control relies on prompt and exact determination of the operating parameters.

Here, gas analysis is key for safe and efficient control of process flows, environmental protection and quality assurance. This benefits controlling flue gas emission in power stations or exhaust gas analysis in automotive engineering, as well as the efficient control of air separators or sterile production and packaging in the food industry.

Many of the analysis processes used in these fields require extracting the sample gas. This inevitably also extracts process-related contamination such as particles or moisture. These in turn can impact the measurement results or damage the measuring cells. The sample gas must therefore be conditioned before entering the analyser.

The small TC-Kit sample gas cooler offers a variety of options for installation in gas analysis systems.

Compact design for installation in a gas cooling system

Effective heat release through external fans and cooling ribs

Version 24 V, optionally 230 V/115 V

Protection class IPxxC, with tight installation IP54

One or two gas paths

Stainless steel, glass or PVDF heat exchanger

Adjustable outlet dew point and alarm thresholds

Nominal capacity 104 Btu/

Dew point stability  $\pm 0.2$  °F

MCD400 display module for separate installation

Used in **DNV-GL and LR type-tested** conditioning unit

Compliance with requirements of **MARPOL MEPC.259(68)** of **IMO confirmed**



## Overview

The TC-Kit series consists of various models which can be classified by the number of heat exchangers.

This classification is reflected in the type designation. The exact item number of the model defined by you is determined by the model code in the category ordering information.

Application	Standard applications
Operating temperature	131 °F
1 heat exchanger	TC-Kit 6312
2 heat exchangers	TC-Kit 6322

Additional components which every conditioning system should feature can optionally be connected:

- Peristaltic pump for condensate separation\*,
- Moisture detector,
- Sample gas pump\*,
- Power supply module 230/115 V,
- Alarm output\*,
- Analog output
- Controller for heated line\*\*.

\* Expansion module (option 10 or 11) required.

\*\* Controller (option 01 or 11) required.

This allows for various configurations of cooler and options. We further paid attention to easy access to wear parts and consumables.

## Description of functions

The cooler is controlled by a microprocessor.

The programmable display shows the block temperature in the selected display unit (°C / °F) (factory preset °C). Application-specific settings can easily be configured guided by the menu, using the 5 buttons. For one, this applies to the target outlet dew point, which can be set from 2 to 20 °C (36 to 68 °F) (factory setting 5 °C/41 °F).

And then the warning thresholds can be adjusted for low and excess temperature. These are set relative to the outlet dew point  $T_a$  setting.

For the low temperature the range is  $T_a - 1$  to  $- 3$  K (at a minimum 1 °C cooling block temperature), for the excess temperature the range is  $T_a + 1$  to  $+ 7$  K. The factory settings for both values are 3 K.

The flashing display as well as a red LED on the display module along with the status relay indicate the conditions are below or above the configured warning range (e.g. after switching on).

The outputs are:

A potential-free status output. The relay is activated when the block temperature is within the target range. The output also serves as collective alarm for device faults, moisture ingress, etc.

A switched output for connecting a gas pump. The output uses the same relay as the status output. This output can only be used for pumps designed for 24 VDC operating voltage.

Another relay output is available for switching up to two peristaltic pumps. The pumps are supplied with the mains voltage and can be shut off via the device menu for maintenance purposes.

The TC-Kit can optionally be configured for connecting a heated line, which can be either self-regulating or a heated line regulated by the cooler.

Operation via 115 VAC/230 VAC and using the regulator for a heated line requires the optional expansion module.

**Gas cooler technical data**

**Gas cooler**

Ready for operation	after max. 10 minutes		
Ambient temperature	41 °F to 131 °F		
Gas output dew point preset:	41 °F		
adjustable:	36 °C...68 °F		
Mechanical load	Tested based on DNV-GL CG0339 vibration class A (0.7g) 2 Hz-13.2 Hz Amplitude ± 1.0 mm 13.2 Hz -100 Hz 0.7g acceleration		
Protection rating	IPxxC, with tight installation IP54		
Rack material (outdoors):	Stainless steel, aluminium		
Packaging dimensions	approx. 8.5 x 7.9 x 14.2 in		
Weight without heat exchanger	approx. 8.4 lb (switched-mode power supply + controller) approx. 7.5 lb (at 24 V DC)		
Electrical power input	Base version		Optional switching power supply
	24 V DC		230 V AC      115 V AC
	5 A		0.6 A      1.2 A
	120 W		110 W/140 VA
Status output switching capacity (optional)	max. 250 V AC, 150 V DC 2 A, 50 VA, potential-free		
Electrical Connections	Cable clamp (for 24 V DC) or blade receptacle (for 115/230 V AC)		
Gas connections	Heat exchanger see table "Heat exchanger overview"		
Parts in contact with mediums	Heat exchanger see table "Heat exchanger overview"		

**Technical Data - Options**

**Technical data controller for heated line**

Temperature, preset:	212 °F
adjustable:	104 °F .. 392 °F
Motor power:	max. 1600 W (230 V)/800 W (115 V)
Sensor type:	Pt100, 2-wire
Connection:	693 series socket, 7-pin

Outlet

One heat exchanger

<b>Model TC-Kit 6312</b>	
Rated cooling capacity (at 77 °F)	104 Btu/h
max. ambient temperature	131 °F
Dew point fluctuations static	± 0.1 K
in the entire specification range	± 1.5 K

Two heat exchangers

<b>Model TC-Kit 6322</b>	
Rated cooling capacity (at 77 °F)	104 Btu/h
max. ambient temperature	131 °F
Dew point fluctuations static	± 0.1 K
in the entire specification range	± 1.5 K
Temperature difference between heat exchangers	< 0.5 K

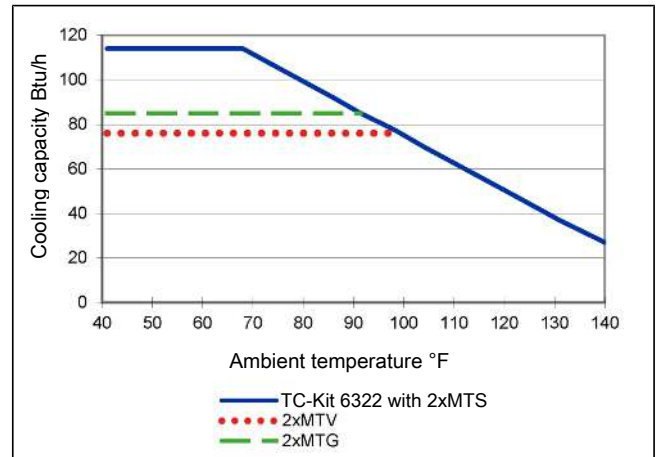
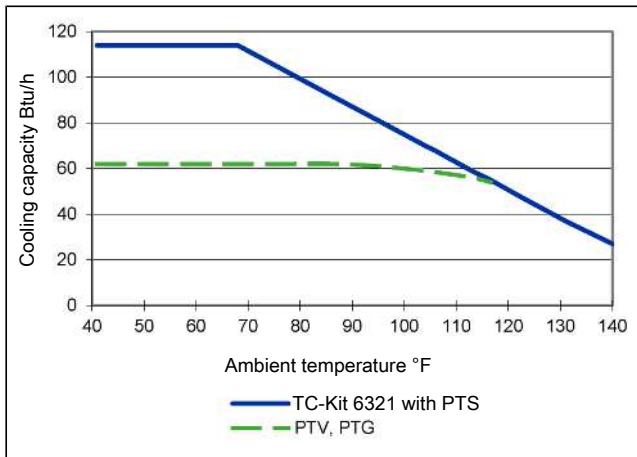

Note: The limit curves for the heat exchangers exchanger PTG, MTG, PTV or MTV apply to a dew point of 122 °F.

The cooling capacity curves of the TC-Kit apply to ideal installation in a housing. Depending how it is installed, the value may deviate from the cooling capacity curve.

Heat exchanger description

The energy content of the sample gas and the required cooling capacity of the gas cooler is determined by three parameters: gas temperature  $\vartheta_G$ , dew point  $\tau_e$  (moisture content) and volume flow  $v$ . The outlet dew point rises with increasing energy content of the gas. The following limits for the maximum flow are specified for a standard operating point of  $T_e = 104$  °F and  $\vartheta_G = 158$  °F. The maximum flow  $v_{max}$  in NI/h of cooled air indicated, so after moisture has condensed. Values may differ for other dew points and gas inlet temperatures. However, the physical facts are so vast we decided to omit the illustration. Please contact our experts for clarification or refer to our calculation program.

Heat exchanger overview

Heat exchanger	PTS PTS-I <sup>2)</sup>	PTG PTG-I	PTV PTV-I <sup>2)</sup>	MTS <sup>3)</sup> MTS-I <sup>2) 3)</sup>	MTG <sup>3)</sup> MTG <sup>3)</sup>	MTV <sup>3)</sup> MTV-I <sup>2) 3)</sup>
Materials in contact with media	Stainless steel	Glass PTFE	PVDF	Stainless steel PVDF	Glass PTFE	PVDF
Flow rate $v_{max}$ <sup>1)</sup>	7.5 lpm	4.2 lpm	4.2 lpm	5 lpm	3.5 lpm	3.2 lpm
Inlet dew point $\tau_{e,max}$ <sup>1)</sup>	149 °F	149 °F	149 °F	149 °F	149 °F	149 °F
Gas inlet temperature $\vartheta_{G,max}$ <sup>1)</sup>	356 °F	284 °F	284 °F	284 °F	284 °F	284 °F
Max. Cooling capacity $Q_{max}$	142 Btu/h	85 Btu/h	85 Btu/h	90 Btu/h	76 Btu/h	62 Btu/h
Gas pressure $p_{max}$	2321 psi	44 psi	29 psi	363 psi	44 psi	29 psi
Pressure drop $\Delta p$ ( $v=2.5$ lpm)	0.15 psi	0.15 psi	0.15 psi	0.29 psi	0.28 psi	0.26 psi
Dead volume $V_{tot}$	1.8 cu. in.	1.8 cu. in.	3.48 cu. in.	1.2 cu. in.	1.1 cu. in.	1 cu. in.
Gas connections (metric)	6 mm	GL 14 (6 mm) <sup>4)</sup>	DN 4/6	6 mm tube	GL14 (6 mm)	DN 4/6
Gas connections (US)	1/4"	GL 14 (1/4") <sup>4)</sup>	1/4"-1/6"	1/4" tube	GL14 (1/4")	1/4"-1/6"
Condensate out connections (metric)	G3/8	GL 25 (12 mm) <sup>4)</sup>	G3/8	G1/4	GL18 (8 mm)	G1/4
Condensate out connections (US)	NPT 3/8"	GL 25 (1/2") <sup>4)</sup>	NPT 3/8"	NPT 1/4"	GL18 (8 mm)	NPT 1/4"

<sup>1)</sup> Max. cooling capacity of the cooler must be considered.

<sup>2)</sup> Models marked I have NPT threads or US tubes, respectively.

<sup>3)</sup> Passive discharge via automatic condensate drains or traps not applicable for MTG heat exchangers. For passive discharge on the MTS and MTV heat exchangers, use a screw connection with a clearance of at least 7 mm (9/32") (see accessories).

<sup>4)</sup> Gasket inside diameter.

Dimensions basic version

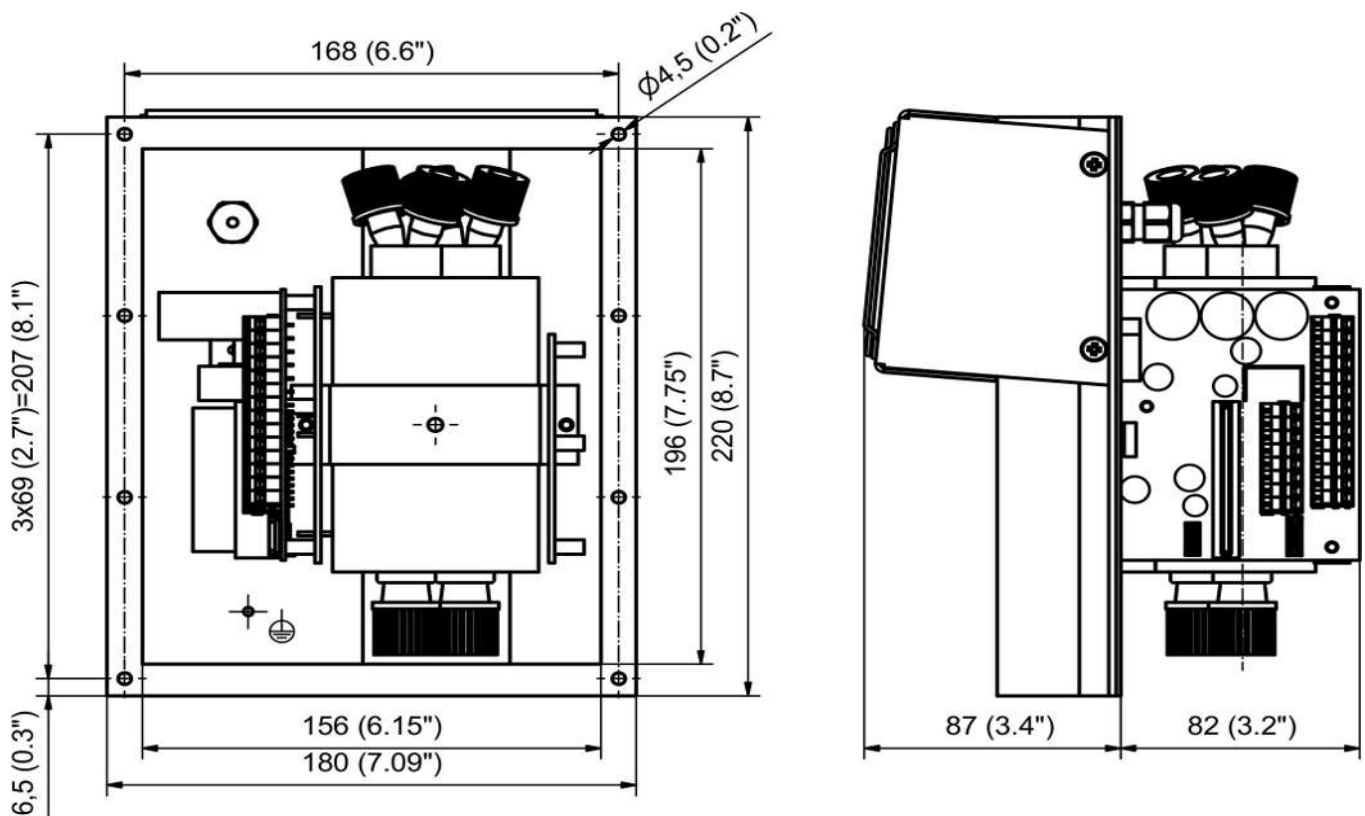

Power supply and expansion module

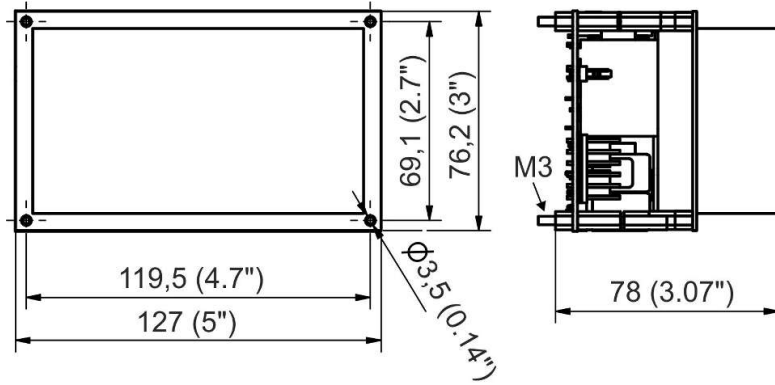

Power supply module

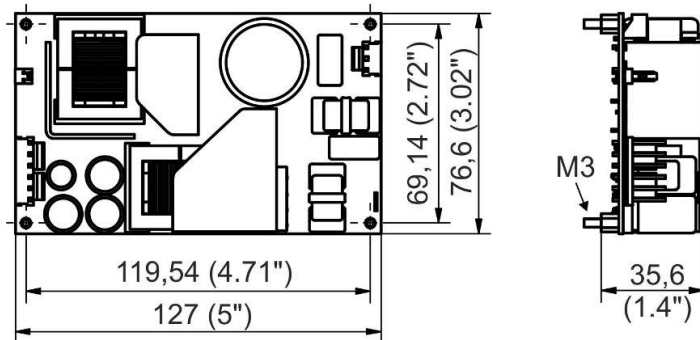

Expansion module (230 V/115 V)

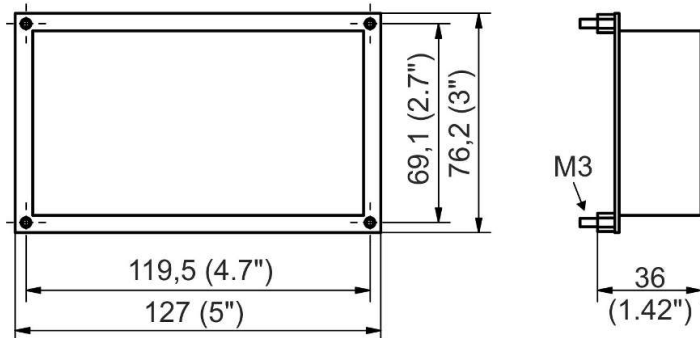

Power board (option expansion module 24 V)

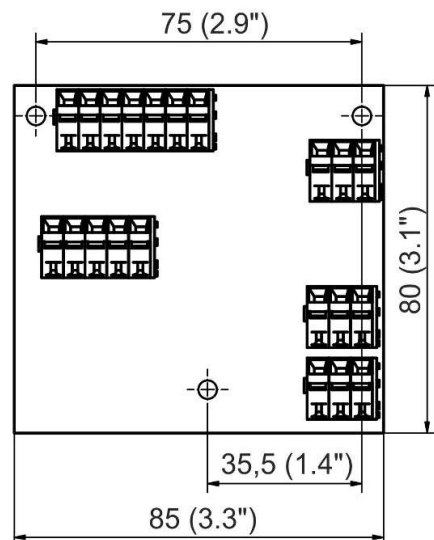

Display unit

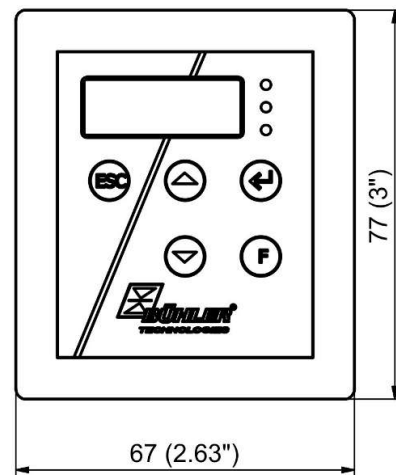

Cut-out in front panel 55.5 x 65.4 mm (2.18" x 2.57")

## Ordering instructions

### Gas cooler models

The item number is a code for the configuration of your unit. Please use the following model code:

4496	2	3	X	X	0	X	X	X	0	Product Characteristics
			1							Gas cooler for 1 heat exchanger
			2							Gas cooler for 2 heat exchangers
										<b>Gas cooler type</b>
			2	0						TC-Kit: Ambient temperature 131 °F
										<b>Supply voltage</b>
						1				115 VAC, 50/60 Hz (power supply module)
						2				230 VAC, 50/60 Hz (power supply module)
						4				24 VDC
										<b>Options</b>
						0	0			Without option
						0	1			Controller for heated line
						1	0			Expansion module
						1	1			Controller and expansion module

### Heat exchanger options

Item no.	Description
4465099	MTS, steel heat exchanger ø20 mm, metric connections
4465099I	MTS-I, steel heat exchanger ø20 mm, US connections
4465299	MTS-WS, steel heat exchanger ø20 mm, horizontal gas inlet/output, metric connections
4465199	MTV, plastic heat exchanger ø20 mm, metric connections
4465199I	MTV-I, plastic heat exchanger ø20 mm, US connections
44651997	MTG, glass heat exchanger ø20 mm, metric and US connections
4447999	PTS, steel heat exchanger ø35 mm, metric connections
4447999I	PTS-I, steel heat exchanger ø35 mm, US connections
4446999	PTV, plastic heat exchanger ø35 mm, metric connections
4446999I	PTV-I, plastic heat exchanger ø35 mm, US connections
4445999	PTG, glass heat exchanger ø35 mm, metric and US connections

### Spare parts and accessories

Item no.	Description
see data sheet 450005	Automatic condensate drain
see data sheet 410011	Moisture detector and flow cell, various models
41111000	Moisture detector connection cable, 4 m (13 ft)
9144050082	Moisture detector connection cable, 450 mm (17.7 in)
9144050038	Cable for cooler temperature analog output 4 m (13 ft)
see data sheet 420011	Sample gas pump P1.x
see data sheet 450020	Peristaltic pump CPsingle, CPdouble and replacement hose
see data sheet 440002	Condensate trap
4381045	Screw connection G1/4 – DN 8/12 for passive condensate connection MTS and MTV
4381048	Screw connection NPT 1/4" for passive condensate connection MTS and MTV
449601000	Analog output kit
449600047	Mains supply, M3 plug, cable length 400 mm (15.7 in)
449600049	Status output, M3 plug, cable length 380 mm (15 in)
449601001	Mounting kit 1 for thin housings