

ModbusRTU

Sample gas cooler RC 1.1

Sample gas coolers are used in extractive gas analysis. The sample gas is taken from the process and may contain impurities such as particles or moisture that can damage the measuring cells or influence the measurement results. For this reason, the moist gas is cooled below the dew point in the sample gas cooler, causing the moisture to condense so it can be removed from the system.

The RC 1.1 is a compressor sample gas cooler designed for efficient cooling performance and high ambient temperatures. Depending on the application, it can be flexibly configured with one or two gas paths. Thanks to its modular design, the RC 1.1 can be individually equipped with integrated humidity sensors, filters and condensate pumps to meet your specific requirements.

The natural refrigerant R600a meets the requirements of Regulation (EU) 2024/573 and is a very environmentally friendly solution thanks to the reduction in CO₂ emissions. At the same time, it ensures the future-proof operation of your systems that comply with legal requirements in the long term.

Efficient cooling with a nominal output of 341 Btu/h

Accurate setting of the gas outlet dew point in a range from 41 °F to 68 °F with a constant dew point stability of ± 0.1 K

Adjustable tolerance ranges (alarm thresholds) for the setpoint temperature of the measuring gas cooler

Ambient temperature from 41 °F to 122 °F

Application-specific selection of heat exchangers: Stainless steel, PVDF or DURAN glass

Future-proof and climate-friendly: Use of natural refrigerants instead of HFC refrigerants

Modular: Moisture detector, filter and condensate pump

Option: Signal output 4 - 20 mA for function and temperature monitoring

Option: Digital output (Modbus RTU) for device configuration and access to process and diagnostic data



Overview

The RC 1.1 series was designed specifically for high cooling capacities and high ambient temperatures.

The compressor coolers are distinguished by two types based on the cooling nests. This classification is reflected in the type designation. The exact item number of the model defined by you is determined by the model code in the ordering information category.

| Application | Cooler model | Heat exchanger |
|-------------|--------------|-------------------------------------|
| Standard | RC 1.1 | 1 heat exchanger (single or double) |

Additional components which every conditioning system should feature can optionally be integrated:

- Peristaltic pump for condensate separation
- Filter,
- Moisture detector.

In addition, we offer a range of signal outputs:

- Status output,
- Analogue output, 4...20 mA, incl. status output,
- Modbus RTU digital output, incl. status output.

This allows for various configurations of the cooler and its options. Here the approach is to simplify the creation of a complete system in a cost-efficient way using pre-installed components with hoses connected. We also prioritised easy access to wear parts and consumables.

Gas cooler technical data

| Gas Cooler Technical Data | | | |
|-------------------------------------------------------------------------------------------|----------------------------------------------------------------------------------------------------------------|----------------------|----------------------|
| Rated cooling capacity (at 77 °F): | 341 Btu/h | | |
| Ambient temperature: | 41 °F to 122 °F | | |
| Ready for operation: | after max. 15 minutes | | |
| Gas outlet dew point preset: | 41 °F | | |
| adjustable: | 37 °F to 68 °F | | |
| Dew point fluctuations static: | ± 0.1 K | | |
| in the entire specification range: | ± 1.5 K | | |
| IP rating: | IP 20 | | |
| Installation: | Table-top or wall mounting | | |
| Housing: | Stainless steel | | |
| Packaging dimensions: | approx. 20.87 x 15.75 x 15.75 in | | |
| Weight: | approx. 33 lb | | |
| max. altitude: | Altitudes up to 3281 ft | | |
| Refrigerant quantity [oz]: | R600a (0.98 oz) | | |
| Electrical connection: | Plug per DIN EN 175301-803 | | |
| Contamination level: | 2 | | |
| Overvoltage category: | II | | |
| Electrical data: <i>Available options may result in details that differ from these</i> | Supply voltage: | 230 V | 115 V |
| | Tolerance: | +/-10% | +/-10% |
| | Frequency: | 50 Hz / 60 Hz | 60 Hz |
| | Typical power input: | 414 VA | 345 VA |
| | max. operating current: | 1.8 A | 3.0 A |
| | Starting current: | 2.3 A | 3.6 A |
| | Protection: | 4 A (delayed action) | 4 A (delayed action) |
| Status output switching capacity: | max. 250 V AC, 150 V DC 2 A, 50 VA, potential-free | | |
| Gas connections and condensate outlet: | For heat exchanger, see table "Heat exchanger overview" For condensate pump, see "Technical Data - Options" | | |
| Parts in contact with media | | | |
| Filter: | see "Technical Data - Options" | | |
| Moisture detector: | see "Technical Data - Options" | | |
| Heat exchanger: | see table "Heat Exchanger Overview" | | |
| Peristaltic pump: | see "Technical Data - Options" | | |
| Tubing: | PTFE/FKM (Viton) | | |

Technical Data - Options

Analogue Output Technical Data

| | |
|-------------|-------------------------------------------------------------------------------|
| Signal: | 4-20 mA or 2-10 V corresponds to -4 °F to 140 °F cooling block temperature |
| Connection: | M12x1 connector, DIN EN 61076-2-101 |

Technical Data, digital output

| | |
|-------------|-------------------------------------|
| Signal: | Modbus RTU (RS-485) |
| Connection: | M12x1 connector, DIN EN 61076-2-101 |

Technical Data Cpsingle/CPdouble Condensate Pump

| | |
|----------------------|------------------------------------------------------------------------------|
| Ambient temperature: | 32 °F to 140 °F |
| Voltage tolerance: | ± 5% |
| Flow rate: | 0.3 L/h (50 Hz)/0.36 L/h (60 Hz) with standard hose |
| Inlet vacuum: | max. 11.6 psi |
| Inlet pressure: | max. 14.5 psi |
| Outlet pressure: | 14.5 psi |
| Weight: | CPsingle-OEM: 1 lb CPdouble-OEM: 1.1 lb |
| Hose: | 4 x 1.6 mm (0.06 in) |
| Condensate outlet: | Hose nipple Ø5 mm (0.24 in) Screw connection 4/6 (metric), 1/6"-1/4" (US) |
| IP rating: | IP 40 |
| Materials | |
| Hose: | Tygon (Norprene) |
| Connections: | PVDF |

Technical Data FF-3-N Moisture Detector

| | |
|--------------------------------------|---------------------------------------------------------|
| Ambient temperature: | 37 °F to 122 °F |
| max. operating pressure with FF-3-N: | 29 psi |
| Weight: | 0.09 lb (incl. cable) |
| Material: | PVDF, PTFE, epoxy resin, stainless steel 1.4571, 1.4576 |

Technical Data Filter AGF-PV-30-F2-L

| | |
|--------------------------------------|-------------------------------------------------|
| Ambient temperature: | 37 °F to 212 °F |
| max. operating pressure with filter: | 58 psi |
| Weight: | 0.20 lb |
| Filter surface: | 19.4 in ² |
| Filter fineness: | 2 µm |
| Dead volume: | 6.59 cu. in. |
| Materials | |
| Filter: | PVDF, DURAN glass (parts in contact with media) |
| Seal: | FKM (Viton) |
| Filter element: | sintered PTFE |

Diagram typical installation

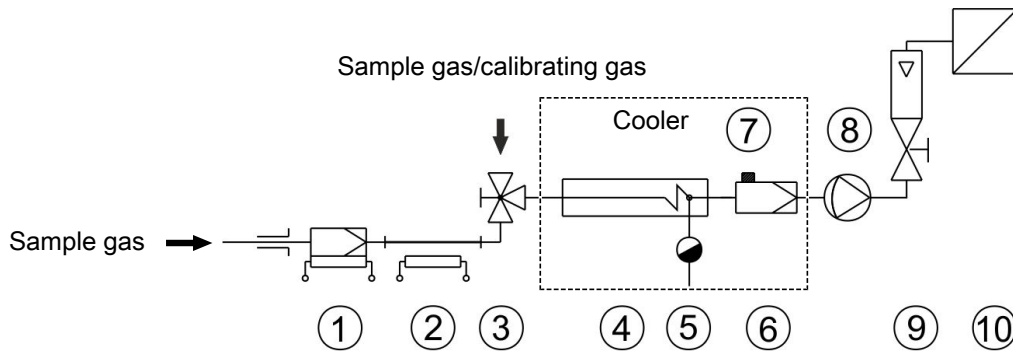

| | |
|--------------------------------------------------|-------------------|
| 1 Sample gas probe | 2 Sample gas line |
| 3 Reversing tap | 4 Heat exchanger |
| 5 Automatic condensate drain or peristaltic pump | 6 Fine filter |
| 7 Moisture detector | 8 Sample gas pump |
| 9 Flow meter | 10 Analyser |

See data sheets for individual component models and data.

Performance data

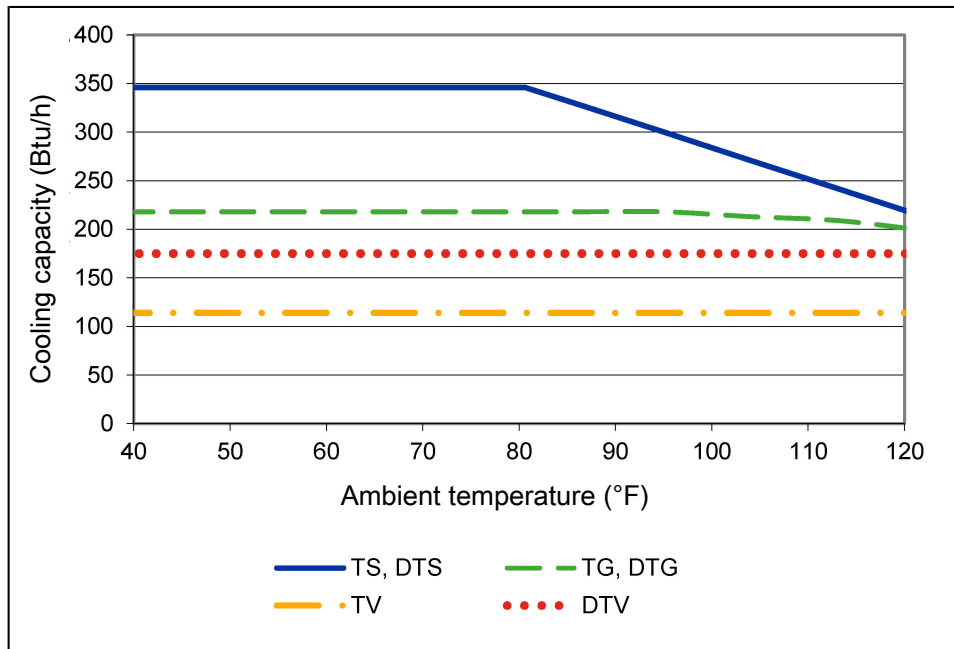

Note: The limit curves for the heat exchangers exchanger apply to a dew point of 149 °F.

Heat exchanger description

The energy content of the sample gas and the required cooling capacity of the gas cooler is determined by three parameters: gas temperature ϑ_G , (inlet) dew point τ_e (moisture content) and volume flow v . The outlet dew point rises with increasing energy content of the gas. The approved energy load from the gas is therefore determined by the tolerated rise in the dew point.

The following limits are specified for a normal standard operating point of $\tau_e = 149\text{ °F}$ and $\vartheta_G = 194\text{ °F}$. The maximum volume flow v_{\max} in NI/h of cooled air is indicated, so after moisture has condensed.

If the values fall below τ_e and ϑ_G , the flow v_{\max} may be increased. For example, on the TG heat exchanger the parameter triple $\tau_e = 149\text{ °F}$, $\vartheta_G = 194\text{ °F}$ and $v = 4.7\text{ lpm}$ may also be used in place of $\tau_e = 122\text{ °F}$, $\vartheta_G = 176\text{ °F}$ and $v = 6.3\text{ lpm}$.

Please contact our experts for clarification or refer to our design program.

Heat exchanger overview

| Heat exchanger | TS TS-I ²⁾ | TG TG | TV TV-I ²⁾ | DTS (DTS-6 ³⁾) DTS-I (DTS-6-I ³⁾) ²⁾ | DTG DTG | DTV ³⁾ DTV-I ²⁾ ³⁾ |
|----------------------------------------------------------|--------------------------|-----------------------------|--------------------------|----------------------------------------------------------------------------|----------------------------|--------------------------------------------------------|
| Materials in contact with media | Stainless steel | DURAN Glas PTFE | PVDF | Stainless steel | DURAN Glas PTFE | PVDF |
| Weight | 2 lb | 0.9 lb | 0.6 lb | 2 lb | 1 lb | 1.2 lb |
| Flow rate v_{\max} ¹⁾ | 8.9 lpm | 4.7 lpm | 2.6 lpm | 2 x 4.2 lpm | 2 x 2.3 lpm | 2 x 2 lpm |
| Inlet dew point $\tau_{e,\max}$ ¹⁾ | 175 °F | 175 °F | 149 °F | 175 °F | 149 °F | 149 °F |
| Gas inlet temperature $\vartheta_{G,\max}$ ¹⁾ | 356 °F | 284 °F | 284 °F | 356 °F | 284 °F | 284 °F |
| Max. cooling capacity Q_{\max} | 427 Btu/h | 218 Btu/h | 114 Btu/h | 427 Btu/h | 218 Btu/h | 175 Btu/h |
| Gas pressure p_{\max} | 2321 psi | 44 psi | 44 psi | 363 psi | 44 psi | 29 psi |
| Pressure drop Δp ($v=2.5\text{ lpm}$) | 0.12 psi | 0.12 psi | 0.12 psi | 0.1 psi each | 0.1 psi each | 0.22 psi each |
| Dead volume V_{dead} | 4.2 cu. in. | 2.9 cu. in. | 7.9 cu. in. | 1.7 / 1.5 cu. in. | 1.7 / 1.5 cu. in. | 1.3 / 1.3 cu. in. |
| Gas connections (metric) | G1/4 | GL 14 (6 mm) ⁴⁾ | DN 4/6 | 6 mm tube | GL14 (6 mm) ⁴⁾ | DN 4/6 |
| Gas connections (US) | NPT 1/4" | GL 14 (1/4") ⁴⁾ | 1/4"-1/6" | 1/4" tube | GL14 (1/4") ⁴⁾ | 1/4"-1/6" |
| Condensate out connection (metric) | G3/8 | GL 25 (12 mm) ⁴⁾ | G3/8 | Tube 10 mm (6 mm) | GL18 (10 mm) ⁴⁾ | DN 5/8 |
| Condensate out connection (US) | NPT 3/8" | GL 25 (1/2") ⁴⁾ | NPT 3/8" | Tube 3/8" (1/4") | GL18 (3/8") ⁴⁾ | 3/16"-5/16" |

¹⁾ Max. cooling capacity of the cooler must be considered.

²⁾ Models marked I have NPT threads or US tubes, respectively.

³⁾ Condensate drain only possible with condensate pump.

⁴⁾ Gasket inside diameter.

Dimensions

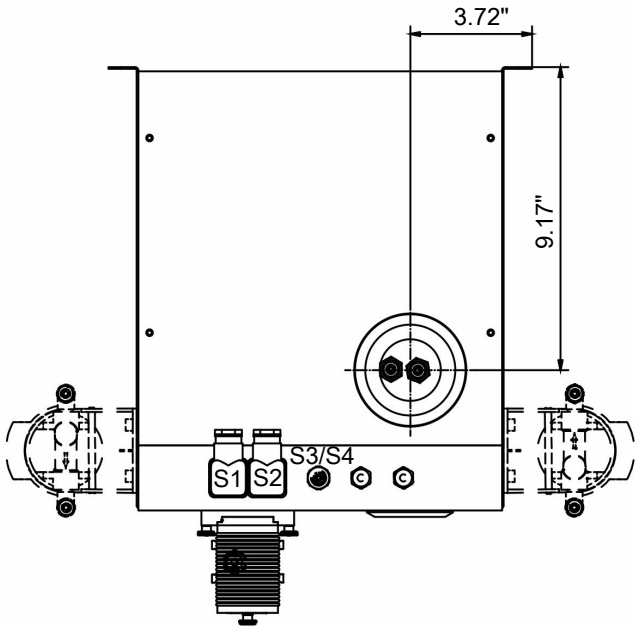
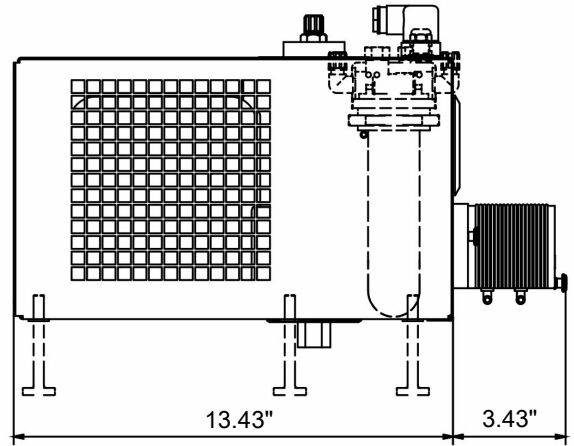
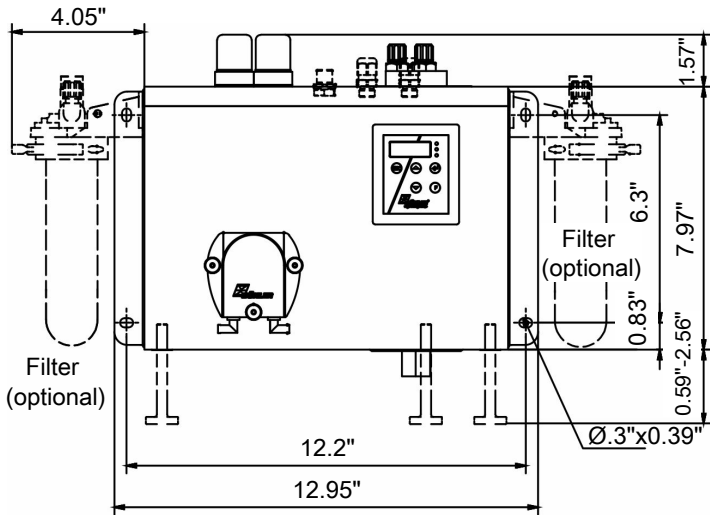

- S1 = Electric supply
- S2 = Status output
- S3/S4 = Analog/digital output (optional)

Ordering instructions

Gas cooler with one gas path inside the heat exchanger

The item number is a code for the configuration of your unit. Please use the following model code:

| | | | | | | | | | | | | | | | | | | | |
|-------------------------------------|---|---|---|---|---|---|---|---|---|---|---|---|---|---|---|---|---|---|------------------------------------------------|
| 4596 | 3 | 1 | 1 | 0 | X | X | X | X | X | 0 | X | X | X | 0 | 0 | 0 | 0 | 0 | Product characteristic |
| Power supply | | | | | | | | | | | | | | | | | | | |
| 1 | | | | | | | | | | | | | | | | | | | 115 V AC, 60 Hz |
| 2 | | | | | | | | | | | | | | | | | | | 230 V AC, 50/60 Hz |
| Heat exchanger | | | | | | | | | | | | | | | | | | | |
| 1 | 1 | 0 | | | | | | | | | | | | | | | | | Stainless steel, TS, metric |
| 1 | 1 | 5 | | | | | | | | | | | | | | | | | Stainless steel, TS-I, US |
| 1 | 2 | 0 | | | | | | | | | | | | | | | | | Duran glass, TG, metric |
| 1 | 2 | 5 | | | | | | | | | | | | | | | | | Duran glass, TG, US |
| 1 | 3 | 0 | | | | | | | | | | | | | | | | | PVDF, TV, metric |
| 1 | 3 | 5 | | | | | | | | | | | | | | | | | PVDF, TV-I, US fittings |
| Condensate drain | | | | | | | | | | | | | | | | | | | |
| 0 | | | | | | | | | | | | | | | | | | | without condensate drain |
| 1 | | | | | | | | | | | | | | | | | | | CPsingle with hose nipple, angled |
| 3 | | | | | | | | | | | | | | | | | | | CPsingle with screw connection, metric/US |
| Filter and moisture detector | | | | | | | | | | | | | | | | | | | |
| 0 | 0 | | | | | | | | | | | | | | | | | | without filter, without moisture detector |
| 0 | 1 | | | | | | | | | | | | | | | | | | without filter, 1 moisture detector |
| 0 | 3 | | | | | | | | | | | | | | | | | | Moisture detector in stainless steel adapter |
| 3 | 0 | | | | | | | | | | | | | | | | | | 1 filter, without moisture detector |
| 3 | 1 | | | | | | | | | | | | | | | | | | 1 filter, 1 moisture detector |
| Signal outputs | | | | | | | | | | | | | | | | | | | |
| 0 | | | | | | | | | | | | | | | | | | | status output only |
| 1 | | | | | | | | | | | | | | | | | | | Analogue output, 4..20 mA, incl. status output |
| 2 | | | | | | | | | | | | | | | | | | | Modbus RTU digital output, incl. status output |

Gas cooler with two gas paths inside the heat exchanger

The item number is a code for the configuration of your unit. Please use the following model code:

| | | | | | | | | | | | | | | | | | | | | | | | | | | | | | | | | | | | | | | |
|------|---|---|---|---|---|---|---|---|---|---|---|---|---|---|---|---|---|---|-------------------------------------|------------------------|---|--|--|--|--|--|--|--|--|--|--|--|--|--|--|--|------------------|-------------------------------------------------|
| 4596 | 3 | 1 | 1 | 0 | X | X | X | X | X | 0 | X | X | X | 0 | 0 | 0 | 0 | 0 | 0 | Product characteristic | | | | | | | | | | | | | | | | | | |
| | | | | | | | | | | | | | | | | | | | Power supply | | | | | | | | | | | | | | | | | | | |
| | | | | | | | | | | | | | | | | | | | 1 | | | | | | | | | | | | | | | | | | 115 V AC / 60 Hz | |
| | | | | | | | | | | | | | | | | | | | 2 | | | | | | | | | | | | | | | | | | | 230 V AC, 50/60 Hz |
| | | | | | | | | | | | | | | | | | | | Heat exchanger | | | | | | | | | | | | | | | | | | | |
| | | | | | | | | | | | | | | | | | | | 2 | 6 | 0 | | | | | | | | | | | | | | | | | Stainless steel, DTS, metric |
| | | | | | | | | | | | | | | | | | | | 2 | 6 | 1 | | | | | | | | | | | | | | | | | Stainless steel, DTS-6 ¹⁾ , metric |
| | | | | | | | | | | | | | | | | | | | 2 | 6 | 5 | | | | | | | | | | | | | | | | | Stainless steel, DTS-I, US |
| | | | | | | | | | | | | | | | | | | | 2 | 6 | 6 | | | | | | | | | | | | | | | | | Stainless steel, DTS-6-I ¹⁾ , US |
| | | | | | | | | | | | | | | | | | | | 2 | 7 | 0 | | | | | | | | | | | | | | | | | Duran glass, DTG, metric |
| | | | | | | | | | | | | | | | | | | | 2 | 7 | 5 | | | | | | | | | | | | | | | | | Duran glass, DTG, US |
| | | | | | | | | | | | | | | | | | | | 2 | 8 | 0 | | | | | | | | | | | | | | | | | PVDF, DTV ¹⁾ , metric |
| | | | | | | | | | | | | | | | | | | | 2 | 8 | 5 | | | | | | | | | | | | | | | | | PVDF, DTV-I ¹⁾ , US |
| | | | | | | | | | | | | | | | | | | | Condensate drain | | | | | | | | | | | | | | | | | | | |
| | | | | | | | | | | | | | | | | | | | 0 | | | | | | | | | | | | | | | | | | | without condensate drain |
| | | | | | | | | | | | | | | | | | | | 2 | | | | | | | | | | | | | | | | | | | CPdouble with hose nipple, angled |
| | | | | | | | | | | | | | | | | | | | 4 | | | | | | | | | | | | | | | | | | | CPdouble with screw connection, metric/US |
| | | | | | | | | | | | | | | | | | | | Filter and moisture detector | | | | | | | | | | | | | | | | | | | |
| | | | | | | | | | | | | | | | | | | | 0 | 0 | | | | | | | | | | | | | | | | | | without filter, without moisture detector |
| | | | | | | | | | | | | | | | | | | | 0 | 1 | | | | | | | | | | | | | | | | | | without filter, 1 moisture detector |
| | | | | | | | | | | | | | | | | | | | 0 | 2 | | | | | | | | | | | | | | | | | | without filter, 2 moisture detectors |
| | | | | | | | | | | | | | | | | | | | 0 | 3 | | | | | | | | | | | | | | | | | | 1 moisture detector in stainless steel adapter |
| | | | | | | | | | | | | | | | | | | | 0 | 4 | | | | | | | | | | | | | | | | | | 2 moisture detectors in stainless steel adapter |
| | | | | | | | | | | | | | | | | | | | 3 | 0 | | | | | | | | | | | | | | | | | | 1 filter, without moisture detector |
| | | | | | | | | | | | | | | | | | | | 3 | 1 | | | | | | | | | | | | | | | | | | 1 filter, 1 moisture detector |
| | | | | | | | | | | | | | | | | | | | 3 | 2 | | | | | | | | | | | | | | | | | | 1 filter, 2 moisture detectors |
| | | | | | | | | | | | | | | | | | | | 4 | 0 | | | | | | | | | | | | | | | | | | 2 filters, without moisture detector |
| | | | | | | | | | | | | | | | | | | | 4 | 1 | | | | | | | | | | | | | | | | | | 2 filters, 1 moisture detector |
| | | | | | | | | | | | | | | | | | | | 4 | 2 | | | | | | | | | | | | | | | | | | 2 filters, 2 moisture detectors |
| | | | | | | | | | | | | | | | | | | | Signal outputs | | | | | | | | | | | | | | | | | | | |
| | | | | | | | | | | | | | | | | | | | 0 | | | | | | | | | | | | | | | | | | | status output only |
| | | | | | | | | | | | | | | | | | | | 1 | | | | | | | | | | | | | | | | | | | Analogue output, 4..20 mA, incl. status output |
| | | | | | | | | | | | | | | | | | | | 2 | | | | | | | | | | | | | | | | | | | Modbus RTU digital output, incl. status output |

¹⁾ Condensate outlets only suitable for connecting condensate pumps (CPdouble).

Spare Parts and Accessories

| Item no. | Description |
|-----------------------|-----------------------------------------------------|
| 41020050 | Filter element F2-L; unit 2 count (for type RC 1.1) |
| 41030050 | Filter element F2; unit 5 count (for type RC 1.2+) |
| 9144050143 | Modbus RTU connection cable 2 m (6.6 ft) |
| 9144050144 | Modbus RTU connection cable 5 m (16.4 ft) |
| 4410001 | Automatic condensate drain 11 LD V 38 |
| 4410004 | Automatic condensate drain AK 20, PVDF |
| 4410005 | Condensate trap GL 1; glass, 0.4 l |
| 4410019 | Condensate trap GL 2; glass, 1 L |
| 459600026 | Adapter plate EGK 1/2 to RC 1.1 and RC 1.2+ |
| see data sheet 410001 | Fine mesh filter AGF-PV-30 |
| see data sheet 450020 | Peristaltic condensate pumps CPsingle, CPdouble |