



# Level and temperature switch

## NT M...-Atex

The NT M...-Atex is used to monitor the liquid level and temperature in simple hydraulic systems. This series consists of simple electrical equipment without a separate voltage source. In the case of intrinsically safe connections as per EN 60079-14, the level switch can be used in Zone 2 (group IIC, device category 3G) explosive areas; this also applies to the inner zone of the tank. The NT M...-Atex can be used in temperature class T4.

This unit further has a particularly buoyant float despite its small dimensions. The bistable reed contacts can later be adjusted.

---

ATEX applications: Zone 2 (cat. 3G), simple electric equipment according to EN 60079-11

Various plug options

Level/temperature monitoring

Adjustable level contacts

Bistable = only one float

Particularly buoyant float

Connector standard

Easy installation

Maintenance free

---



**Technical Data**

**NT M...-Atex**

Operating pressure:	max. 1 bar	
Medium /operating temperature:	max. +80 °C (C7 and M3 plug) max. +70 °C (M12 plug)	
Ambient temperature:	-20 to +80 °C (C7 and M3 plug) -20 to +70 °C (M12 plug)	
Fluid density:	min. 0.8 kg/dm <sup>3</sup>	
<b>Material</b>	<b>MS</b>	<b>VA</b>
Switching tube:	Brass	1.4571
Flange:	Brass	1.4571
Float SK 161	NBR	NBR
<b>Level contacts</b>	<b>K8</b>	<b>W9</b>
Function	NC/NO*	Changeover contact
Min. contact spacing	40 mm	40 mm
<b>Temperature contacts</b>		
Switch-back difference:	15 K ± 5 K	
Switching point:		
	<b>NC*</b>	<b>NO*</b>
50 °C	TMÖ-50	-
55 °C	-	TMS-55
60 °C	TMÖ-60	TMS-60
70 °C	TMÖ-70	TMS-70
80 °C	TMÖ-80	TMS-80

Other temperatures available upon request

\*NC = NC contact/NO = NO contact All data for rising temperature

**Pt100 resistance thermometer**

(Pt100 class B DIN / IEC 751)

Tolerance:	± 0.8 K
Measuring current $I_c$ :	≤ 1 mA
$P_i$ :	100 mW
$U_i$ :	30 V
$I_i$ :	50 mA
$L_i, C_i$ :	negligible

**Accessories**

Connection cable M12x1 (5-pin) 3.0 m long, item no.: 9144050018

Adapter G3/4 to G1, item no.: 1011000

Adapter G3/4 to oval flange, item no.: 1012000

The device is suitable for use in ATEX category II 3 G Ex ic IIC T4 Gc.

**The level switches may only be operated on intrinsically-safe circuits!**

**Temperature contacts**

$P_i$	100 mW
$U_i$	30 V
$I_i$	50 mA
$L_i; C_i$	Negligible

**Dimensions**

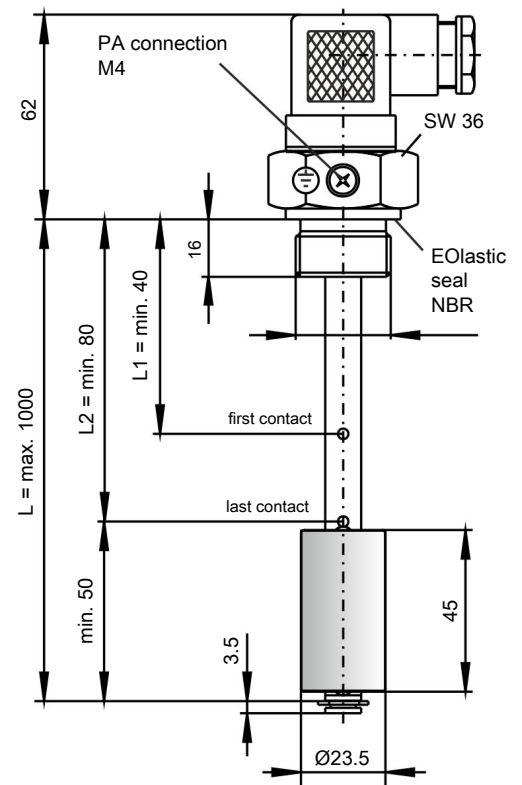

**Model Key**

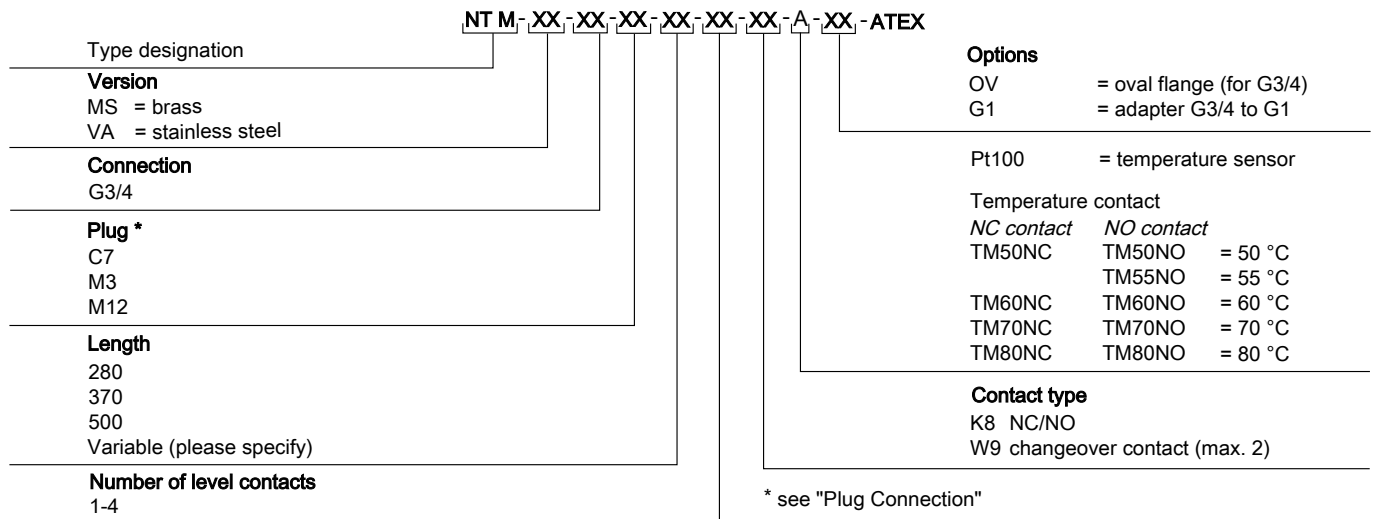

**Ordering example**

You require: Level switch with G3/4 connection, brass, length L= 500 mm,  
2 level contacts, 1st contact 100 mm NC, 2nd contact 450 mm NO

Order NT M-MS-G3/4-M3/500-2K-100NC-450NO-ATEX

**Standard pin assignment**

Connector:	M3 valve connector	M12 plug A coded	C7 HAN 3 A
Dimensions:			
Connection schematic:			
Number of poles:	3-pin + PE	4-pin + PE	7-pin + PE
DIN EN	175301-803	61076-2-101	175301-801
Max. operating voltage:	30 V DC	30 V DC	30 V DC
IP rating:	IP65	IP67*	IP65**
Cable fitting:	PG 11		PG11
Only level contact(s) Type K8 (NC/NO)	<p><b>1 x K...</b></p> <p><b>2 x K...</b></p>	<p><b>1 x K...</b></p> <p><b>2 x K...</b></p>	<p><b>1 x K8</b></p> <p><b>2 x K8</b></p> <p><b>3 x K8</b></p> <p><b>4 x K8</b></p>
Level contact(s) Type K8 (NC/NO) plus temperature contact TK or Pt100 Attention: 2 separate roots			<p><b>1 x K8 + 1 x TK or Pt100</b></p> <p><b>2 x K8 + 1 x TK or Pt100</b></p> <p><b>3 x K8 + 1 x TK or Pt100</b></p>
Level contact(s) type K8 or K10 (NC/NO) plus temperature contact TK	<p><b>1 x K... + 1 x TK</b></p>	<p><b>1 x K... + 1 x TK</b></p>	
Only level contact(s) Type W9 (changeover contact)	<p><b>1 x W...</b></p>	<p><b>1 x W...</b></p>	<p><b>1 x W9</b></p> <p><b>2 x W9</b></p>
Only level contact(s) Type W9 (change-over contact) plus temperature contact TK or Pt100 Attention: 2 separate roots			<p><b>1 x W9 + 1 x TK or Pt100</b></p> <p><b>2 x W9 + 1 x TK or Pt100</b></p>

\*with respective plug top.

\*\*IP 44 with gland/without gasket.