



Bühler Particle Monitor BPM

Continuous particle monitor for lubricating and hydraulic oils

Particles are undesired parameters in hydraulic and lubricating systems and can cause considerable system damage.

The Bühler BPM-100 particle monitor was designed specifically for monitoring particles in oil. Continuously monitoring the fluid for solid particles can extend oil change intervals, thus significantly reduce maintenance costs. This makes the Bühler BPM-100 particle monitor an essential part of your condition monitoring system.

The BPM-100 visually detects particles and uses the principle of light obscuration to properly sort the particles in the respective fluid. Meaning a laser inside the measuring cell rates the particles based on size and quantity. It has the classifications according to common purity classes and features a large range of output signals sent by the switching output, 4-20 mA all the way to digital communication.

BPM-100

Switching output, 4-20 mA and CAN bus

High pressure resistance, primarily used in bypass

Continuous particle monitoring for detailed analysis of machine conditions

Compact, tough housing also suitable for demanding applications

Purity classes according to ISO 4406:99, SAE AS 4059, NAS 1638 & GOST 17216

Quick and accurate detection of particles or particle changes

Easy menu navigation

Easy system connection via Minimes or G1/4"

LC display



Technical Data

BPM-100-000-1DC2S1A	1DC2S1A
Version:	Compact unit with Minimes adapter
Process connection:	G 1/4" and M16x2 Minimes adapter
Material in contact with media:	stainless steel, sapphire, chromium, NBR, Minimes coupling: zinc/nickel
Medium temperature:	-20 °C to +85 °C
Ambient temperature:	-20 °C to +85 °C
Pressure resistance:	420 bar dynamic 600 bar static
Compatible fluids:	mineral oils (H, HL, HLP, HLPD, HVLP), synthetic esters (HETG, HEPG, HEES, HEPR), polyalkylene glycol (PAG), zinc- and ash-free oils (ZAF), poly-alpha-olefins (PAO)
Weight:	720 g
Input value	
Flow range:	50...400 ml/min
Operating voltage (U _b):	9 – 33 V DC
Power input:	max. 0.3 A
Measuring range	
ISO4409:99:	0...28 display 10...22 calibrated
SAE AS 4059E:	0...12 display
Following NAS 1638:	0...12 display
Following GOST 17216:	0...17 display
Size channels:	4, 6, 14, 21 µm
Measuring accuracy in calibrated measuring range	±1 Ordinal number
Additional secondary measurands:	temperature, volume flow, operating hours
1DC output:	RS232/CANopen/SAE J1939
Input/output 2S:	high/low, open collector
1A output:	4-20 mA clocked

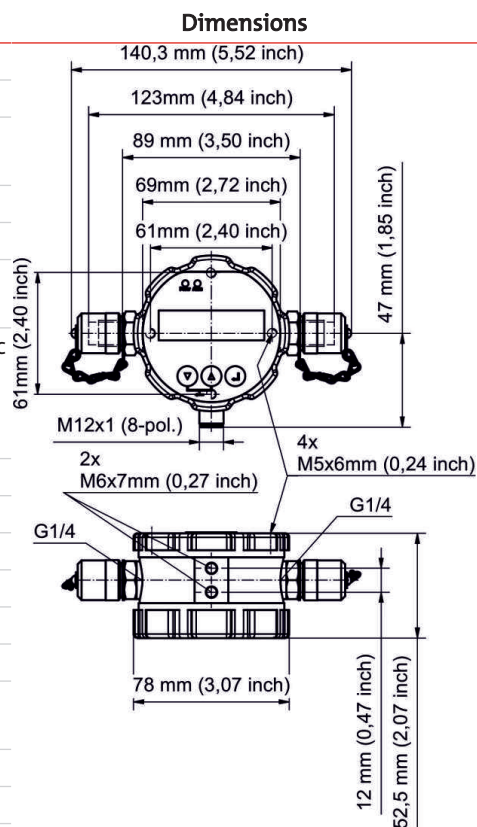

Standard pin assignment

Plug connection	M12 (base)
Number of pins	8-pin
Voltage	max. 33 V DC
IP rating with IP67 cable box attached	IP67
Version	1DC2S1A
Connection schematic	
1	L+
2	L-
3	TxD, CAN low [OUT]
4	RxD, CAN high [IN]
5	Switching input [high/low]
6	Analog output 4...20 mA
7	Switching output [high/low]
8	Signal earth
Shield	-

Pressure loss

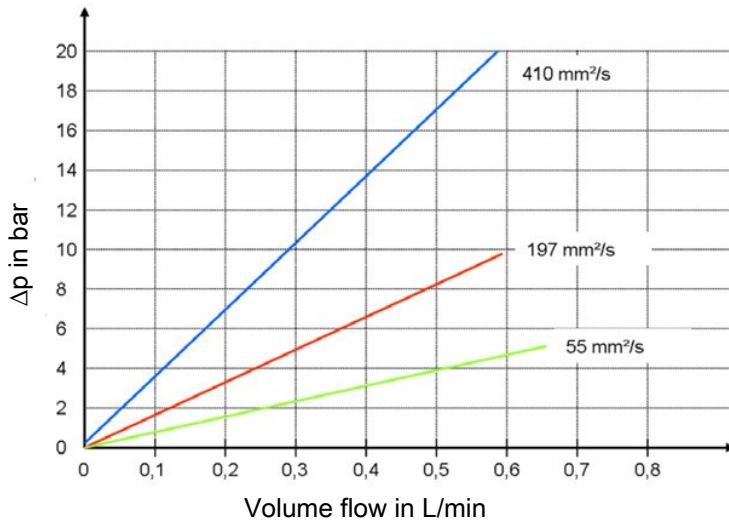

Fig. 1: Flow curve for various viscosities without Minimes connections

Model key

BPM - 100 - □□□ - 1DC2S1A

Type designation

BPM Bühler Particle Monitor

Version

100 Standard compact unit

Display

000 Unit with display

010 Unit without display

Outputs

1DC2S1A

1x RS232/CAN

2x Switching signal input output

1x analogue signal 4...20 mA

Item no.	Model
1530001000	BPM-100-000-1DC2S1A
1530001010	BPM-100-010-1DC2S1A

Accessories

Item no.	Description
1590001006	Recalibration
1590001001	RS232 data cable
1590001002	USB/RS232 adapter
1590001003	Power supply
1590001004	Minimes connection with flow regulator
1590001011	CM terminal (see separate data sheet no. 150107)