

Level switch NS 10/NS 25 ..-AM

Oil tanks in lubrication and oil supply systems are often under overpressure compared to the ambient atmosphere. All oil moistened parts of devices mounted externally on the tanks or housings for monitoring the liquid level must therefore be pressure-resistant.

The NS 10 and NS 25 series are designed for 10 or 25 bar operating pressures. The separate display float can easily be viewed inside the upstream guide tube and the magnetic field ensures the touchless connection with the interior main float. The variable electric switching contacts and/or the continuous position encoder are located on the scale plate, which also holds the sight glass. On the NS 10 it is standard connected to the tank via pipe sockets and fittings or DIN flange, on the NS 25 via DIN flange.

Level switch NS for external installation

Visual and electric liquid level monitoring

Operating pressure up to 25 bar

Lengths up to 5000 mm

Adjustable level contacts

Optional analog output 4-20 mA or IO-Link

Display with scale

Compact design

Particularly buoyant floats

Special versions available upon request

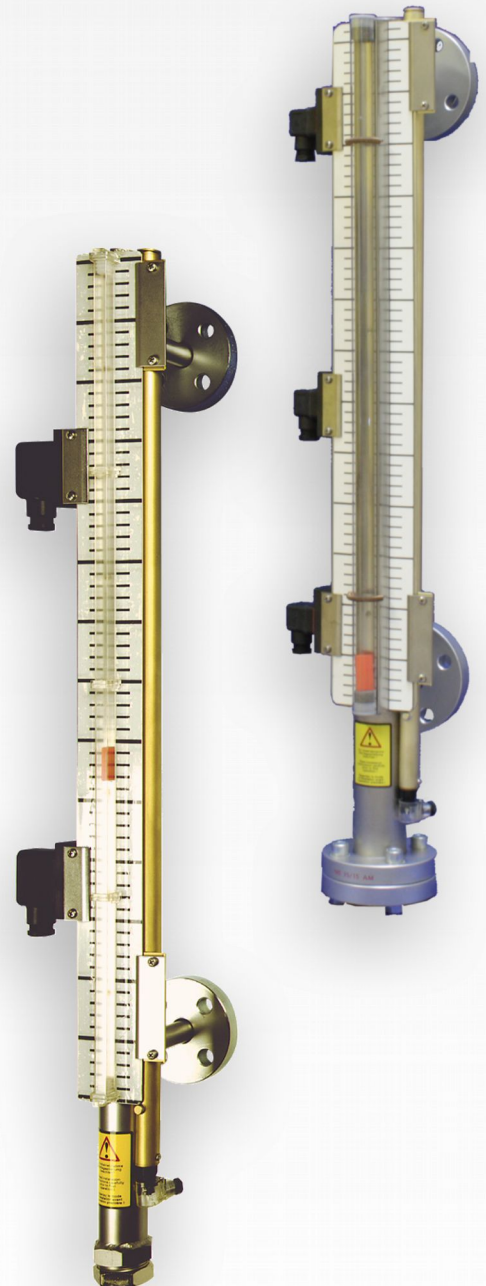

Technical Data NS 10 ..-AM

Basic unit

Max. operating pressure	10 bar
Max. operating temperature	100 °C
spec. min. fluid weight	0.75 kg/dm ³

Material

Float SK166	NBR
Riser	1.4571
Flange	Galvanised steel
Sight glass	PC
Sealing cap	1.4571

Version	0-AM	15-AM	25-AM
Connection	Tube	Flange	Flange
DIN 2656 flange		DN15	DN25
ØD	20	95	115
Øk		65	85
Ød		14	14
b		16	18
ØA		45	68
h		12	14

Weight at L1=500 mm	approx. 7.5 kg	approx. 8.0 kg	approx. 8.75 kg
Weight L1+100 mm	approx. 0.2 kg	approx. 0.2 kg	approx. 0.2 kg

Other versions available upon request

Options

Continuous liquid level measurement BLT or switching contacts, see below

Accessories

Item no.:	Description:
2251000	Flange seal 45/22x2 mm (DN15)
2252000	Flange seal 68/27x2 mm (DN25)
2271999	Mounting bolts 8 x M12x65
9008070	Ball valve, steel DN15 PN16/40
9008002	Ball valve, steel DN25 PN16/40
9008071	Ball valve, stainless steel DN15 PN16/40
9008004	Ball valve, stainless steel DN25 PN16/40

Pressure Equipment Directive information:

The level switches are designed, manufactured and tested to Pressure Equipment Directive 2014/68/EU according to AD-2000 code. The actual category of the level switch achieved is printed on the type plate. Comprehensive quality assurance is performed according to module H.

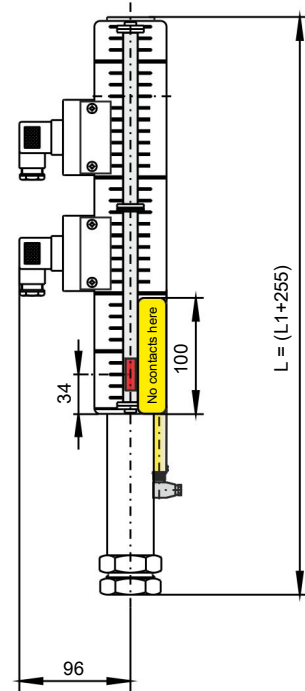
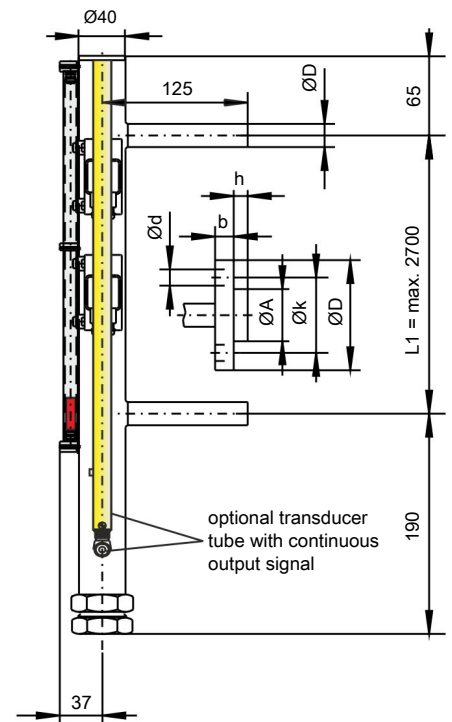

Model key NS 10

Model key

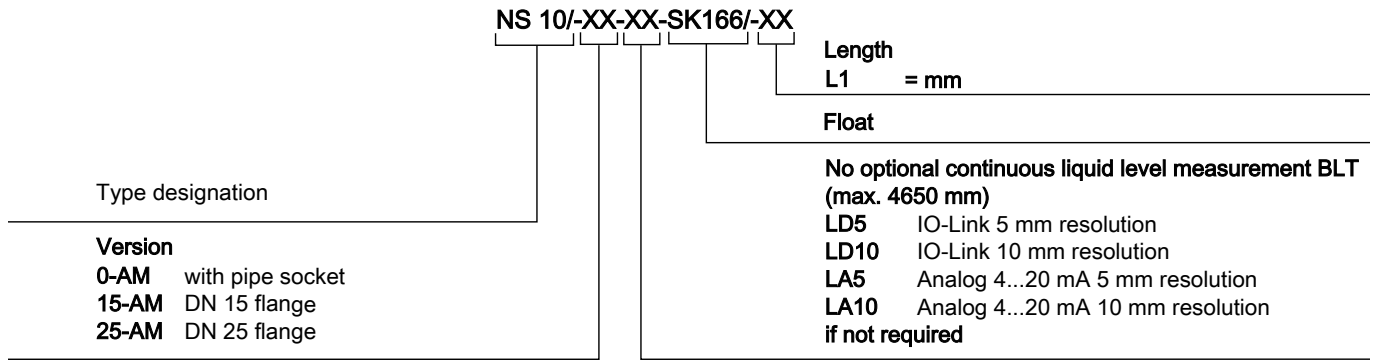

Ordering example:

You require: Level switch for external installation, max. operating pressure 10 bar, with DN15 flange connection, adapter spacing L1 = 1500 mm, with 2 changeover contacts

Order NS 10/15-AM-SK166 / 1500
2 x item no. 28 89 999 contact MKS 1/W

Ordering example with continuous liquid level measurement:

You require: Level switch for tank top installation, operating pressure max. 10 bar, with DN15 flange connection, transducer tube IO-Link 5 mm, adapter spacing L1 = 1500 mm, with 2 changeover contacts

Order NS 10/15-AM-LD5-SK166 / 1500
2 x item no. 28 89 999 contact MKS 1/W

Technical Data NS 25 ..-AM

Basic unit

Operating pressure	max. 25 bar	
Operating temperature	max. 120 °C	
spec. min. fluid weight	SK661	SK662
	0.85 kg/dm ³	0.70 kg/dm ³

Material

Float	1.4571	
Riser	1.4571	
Flange	Galvanised steel	
Sight glass	PC	

Version	15-AM	25-AM
Connection	Flange	Flange
DIN 2656 flange	DN15	DN25
ØD	95	115
Øk	65	85
Ød	14	14
b	16	18
ØA	45	68
h	12	14
S for float SK661	205	205
S for float SK662	390	390
Weight at L1=500 mm	approx. 9.5 kg	approx. 10.5 kg
Weight L1+100 mm	approx. 0.4 kg	approx. 0.4 kg

Other versions available upon request

Options

Continuous liquid level measurement BLT or switching contacts, see below

Accessories

Item no.:	Description:
2251000	Flange seal 45/22x2 mm (DN15)
2252000	Flange seal 68/27x2 mm (DN25)
2271999	Mounting bolts 8 x M12x65
9008070	Ball valve, steel DN15 PN16/40
9008002	Ball valve, steel DN25 PN16/40
9008071	Ball valve, stainless steel DN15 PN16/40
9008004	Ball valve, stainless steel DN25 PN16/40

Pressure Equipment Directive information:

The level switches are designed, manufactured and tested to Pressure Equipment Directive 2014/68/EU according to AD-2000 code. The actual category of the level switch achieved is printed on the type plate. Comprehensive quality assurance is performed according to module H.

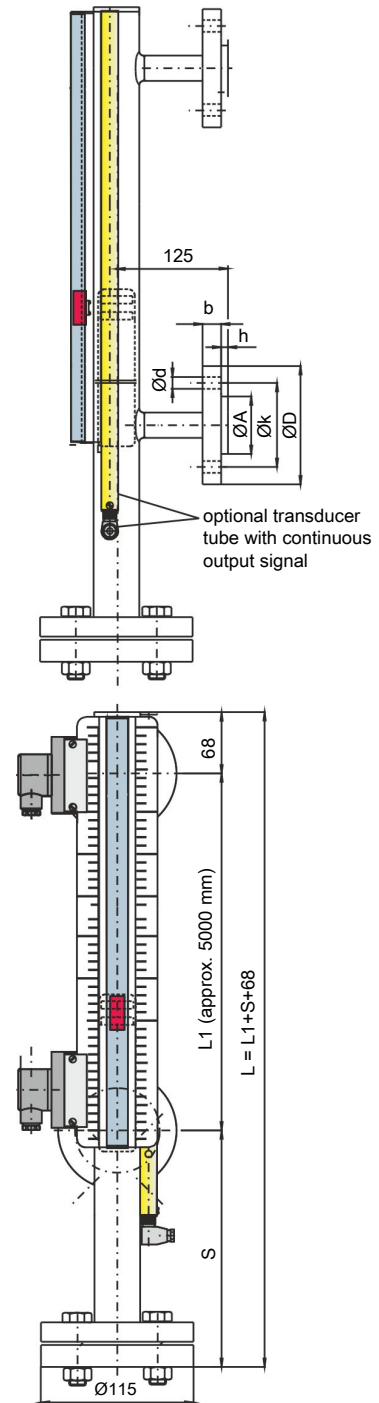

Model key NS 25

Model key

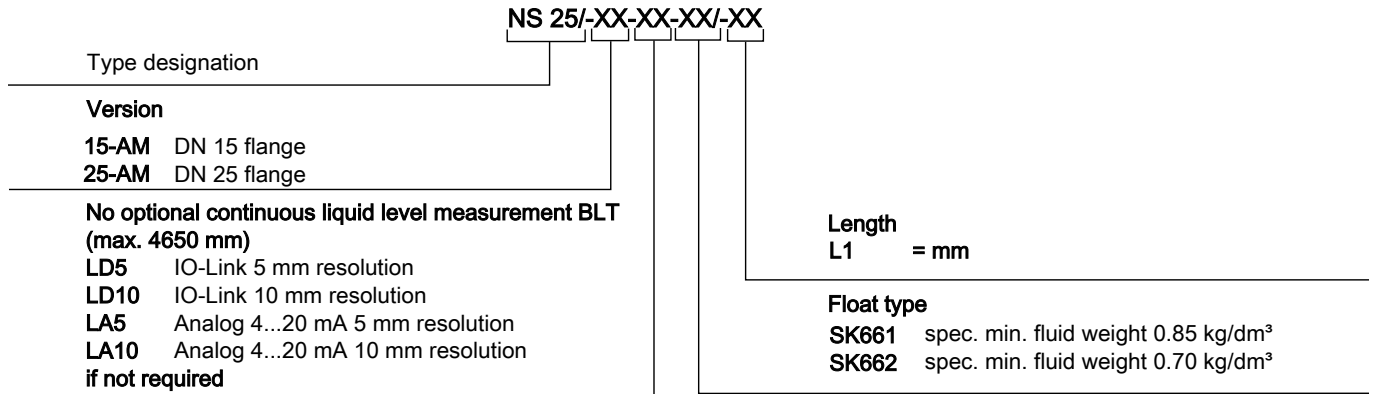

Ordering example:

You require: Level switch for tank top installation, max. operating pressure 25 bar, with DN25 flange connection, spec. Fluid weight 0.89 kg/dm³, adapter spacing L1 = 1500 mm, continuous level output, resolution 10 mm with 4...20 mA signal and 2 changeover contacts

Order NS 25/25-AM-LA10-SK661 / 1500
2 x item no. 28 89 999 contact MKS - 1/W

Contacts for NS ..-AM

Pin Assignment (Contact position empty tank)

Type	MKS-1/K (-60)
Function	NC contact/NO contact
Max. voltage	230 VAC/DC
Max. switching current	1 A
Max. contact load	50 VA
Connector	M3 (DIN EN 175301-803)
	3-pin + PE
IP class	IP 65
Item no.	28 88 999

Mounted left

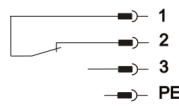

Mounted right

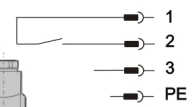

Type	MKS-2/K
Function	2 x NC contact/NO contact
Max. voltage	230 VAC/DC
Max. switching current	1 A
Max. contact load	50 VA
Connector	S6 (DIN EN 175291-804)
	6-pin + PE
IP class	IP 65
Item no.	28 91 999

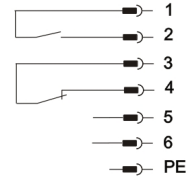
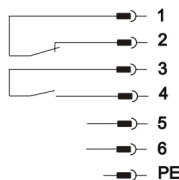

Type	MKS-1/W (-60)
Function	Changeover contact
Max. voltage	230 VAC/DC
Max. switching current	1 A
Max. contact load	50 VA
Connector	M3 (DIN EN 175301-803)
	3-pin + PE
IP class	IP 65
Item no.	28 89 999

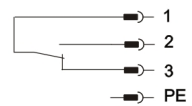
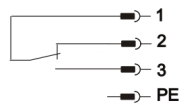

Type	MKS-1/W-L 24 V (-60)
Function	Changeover contact with LED
Max. voltage	24 VDC
Max. switching current	1 A
Max. contact load	25 VA
Connector	S6 (DIN EN 175291-804)
	6-pin + PE
IP class	IP 65
Item no.	28 90 999

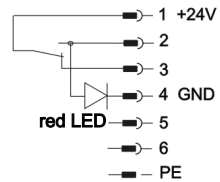
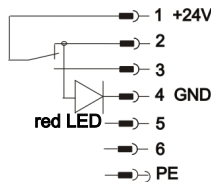

Other contacts available upon request

For applications in high shock and vibration environments we recommend using the MKS-1/K and MKS-2K contacts.

Versions ending in -60 are for switch type NS 3/20 AM and have a pipe clamp for mounting to the level switch tube.

When installing a BLT transducer tube with continuous output signal, the contacts can only be mounted on the left.

MKS 1/K, MKS 1/W

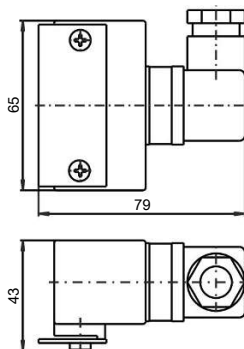

MKS 2/K

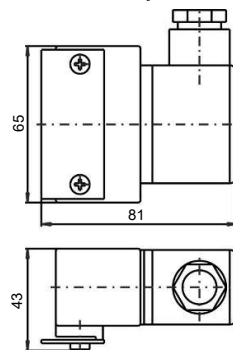

MKS 1/W-L24V

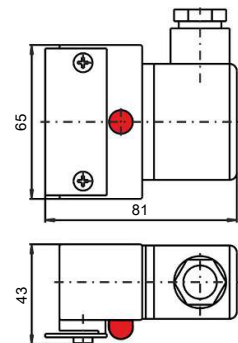

BLT Technical Data

LD-5(10)-1D1S-/VAR with IO-Link interface

LA-5(10)-1A-/VAR with 4-20 mA output

	1D1S	1A
Transducer tube material:	Nickel-plated brass	
Ambient temperature:	-20 °C to +70 °C	
Lengths:	variable to max. 4650 mm	
Input value		
Sensor element:	Reed chain 5 or 10 mm resolution	
Tolerance:	±1% FS	
Operating voltage (UB):	18 - 30 VDC	10 - 30 VDC
Measuring range:	0 to 100 %	4-20 mA > 0-100 %
Output:	IO-Link	4-20 mA
IO-Link		
Baudrate:	Rev. 1.1	-
SIO Mode:	COM3 (230.4k)	-
SIO Mode:	Yes	-
Min. Time Period	10 ms	-
Max. Load:	-	(UB-8V)/0.02 A

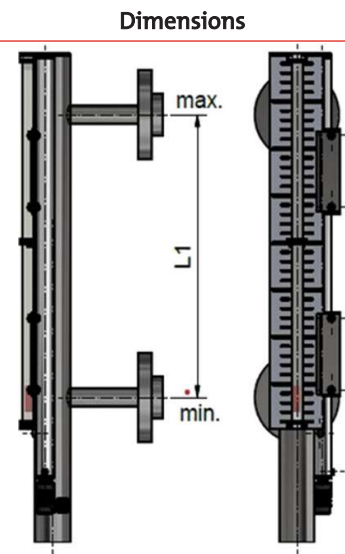

BLT Standard Pin Assignment

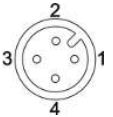
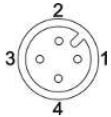
Connector	M12 (base)	M12 (base)
Number of pins	4-pin	4-pin
DIN EN 61076-2-101	30 VDC	30 VDC
IP rating with IP67 cable box attached	IP67	IP67
Version	1D1S	1A
Connection schematic		
	1D1S (IO-Link)	1A (4-20 mA)
1	+24 VDC	+24 VDC
2	S2 (PNP max. 200 mA)	OUT 4-20 mA
3	GND	GND
4	C/Q (IO-Link)	NC