



Sample gas cooler EGK 2-19+

In emission measurement, process control relies on prompt and exact determination of the operating parameters.

Here, gas analysis is the key for safe and efficient control of process flows, environmental protection and quality assurance. This benefits controlling flue gas emission in power stations as well as measurements in small combustion plants or exhaust gas analysis in automotive engineering.

Many of the analysis processes used in these fields require extracting the sample gas. This inevitably also extracts process-related contamination such as particles or moisture. These in turn can impact the measurement results or damage the measuring cells. The sample gas must therefore be conditioned before entering the analyser.

The EGK 2-19+ series features a new generation heat exchangers with a particularly low wash out effect of water-soluble components and are specifically suitable for measuring emissions. Particularly the wash out effect of SO₂ is low. These coolers can therefore be used for so-called automated measuring systems (AMS) per EN 15267-3.

Compact design: fully assembled and ready to connect

Low maintenance costs based on easy accessibility

One gas path

Optimised heat exchanger type 2 in DURAN® glass or PVDF

Adjustable outlet dew point and alarm thresholds

Self-monitoring

Status outputs

Ambient temperatures up to 50 °C

Rated cooling power 320 kJ/h

Dew point stability 0.1 °C

Available as 19" rack or for wall-mounting



Description

Concept

The EGK 2-19+ concept is firstly based on a cooler for two in-line heat exchangers.

In addition, other components which every conditioning system should feature can optionally be integrated:

- Peristaltic pump for condensate separation
- Filter
- Moisture detector

This therefore allows for virtually any configuration of cooler and options. Here the approach is to simplify creating a complete system in a cost-efficient way through pre-installed components with hoses connected. We further paid attention to easy access to consumables, consequently located at the front.

The glass dome allows the dirt level of the filter element to easily be determined.

The moisture detector is easy to remove. This may be required if water enters the cooler due to a malfunction and the peristaltic pump can no longer remove it.



Description of a fully equipped gas path

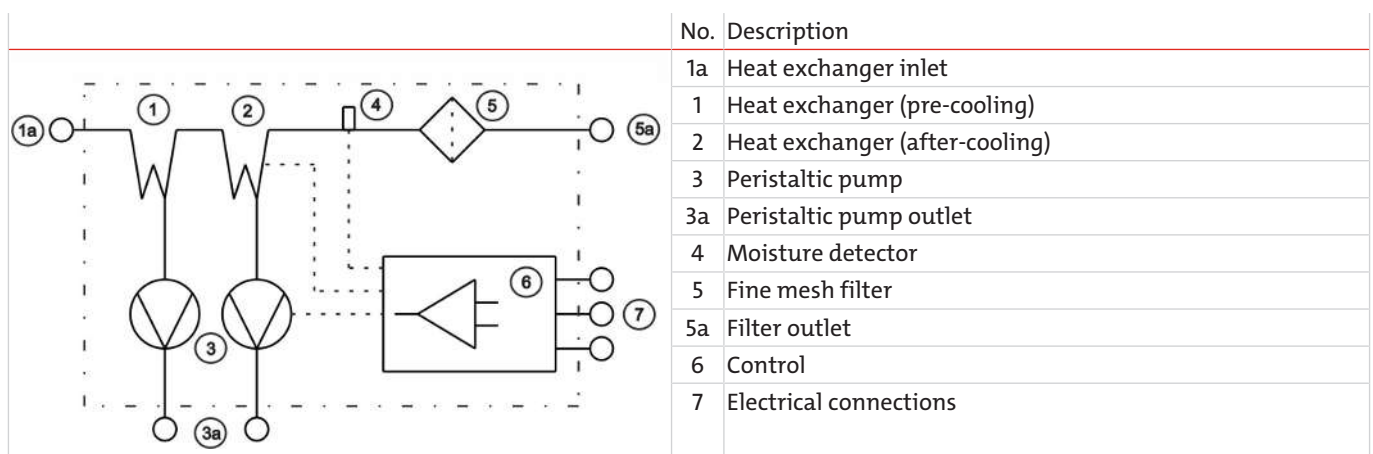

The gas to be conditioned is fed directly into the inlet of the heat exchanger (1, 1a). A hose is pre-installed between the heat exchanger (2) outlet and the fine mesh filter (5). Sample gas is continued directly from the outlet of this filter via hose fitting (5a).

Condensate is removed by the peristaltic pumps (3), the inlet of which is directly connected to the heat exchanger via hose.

A moisture detector (4) may be installed directly into the filter, which is analysed by electronics (6). This eliminates the need to purchase additional controllers.

Control (6)

The control features a microprocessor-controlled Bühler Constant Regulation at its core.

The display with control keys at the front displays the cooler temperature as well as all operating statuses.

Use the keys to set various parameters such as output dew point, alarm limits or the sensitivity of moisture detectors.



Electrical connections (7)

All signals output by the electronics can be accessed via Phoenix plug at the top of the cooler. The electric supply is also a plug connection. This means no fixed wiring is required.

Gas cooler technical data

Gas Cooler Technical Data

Ready for operation:	after max. 15 minutes		
Rated cooling capacity (at 25 °C):	320 kJ/h		
Ambient temperature:	5 °C to 50 °C		
Gas outlet dew temperature, preset:	5 °C		
Dew point fluctuations			
static:	± 0.1 K		
in the entire specification range:	± 1.5 K		
Temperature difference between heat exchangers:	< 0.5 K		
Max. inlet temperature:	see table "Heat Exchanger Overview"		
max. pressure:	see table "Heat Exchanger Overview" Limitations due to filter or peristaltic pump (see Technical Data - Options)		
IP rating:	IP 20		
Housing:	Stainless steel		
Packaging dimensions:	approx. 550 x 430 x 340 mm		
Weight incl. heat exchanger:	approx. 15 kg approx. 18.5 kg at full expansion stage		
Refrigerant (global warming potential):	R134a (GWP 1430)		
Quantity:	75 g		
CO ₂ -equivalent:	0.107 T		
Electric supply:	115 V, 60 Hz or 230 V, 50 Hz Plug per EN 175301-803		
Electrical data:		230 V	115 V
	Typical power input:	140 VA	155 VA
	max. operating current:	1.6 A	3.2 A
Status output switching capacity:	max. 250 V, 2 A Phoenix plug		
Gas connections:	Heat exchanger see table "Heat exchanger overview" Filter DN 4/6 or 1/4"-1/6"		
Condensate outlet:	Hose nipple Ø5 mm		
Parts in contact with mediums			
Filter:	see "Technical Data - Options"		
Moisture detector:	see "Technical Data - Options"		
Heat exchanger:	see table "Heat Exchanger Overview"		
Peristaltic pump:	see "Technical Data - Options"		
Tubing:	PTFE/Viton		

Technical Data - Options**Analogue Output Cooler Temperature Technical Data**

Signal	4-20 mA or 2-10 V corresponds to -20 °C to +50 °C cooler temperature Plug M12x1, DIN EN 61076-2-101
--------	---

Technical Data FF-3-N Moisture Detector

Ambient temperature	3 °C to 50 °C
max. operating pressure with FF-3-N	2 bar
Material	PVDF, PTFE, epoxy resin, stainless steel 1.4571, 1.4576

CPsingle Peristaltic Pumps Technical Data

Flow rate	0.3 L/h (50 Hz) / 0.36 L/h (60 Hz) with standard hose
Vacuum inlet	max. 0.8 bar
Pressure inlet	max. 1 bar
Outlet pressure	1 bar
Hose	4 x 1.6 mm
Protection class	IP 40
Materials	
Hose:	Norprene (standard), Marprene, Fluran
Connections:	PVDF

Technical Data Filter AGF-FA-5

max. operating pressure with filter	2 bar
Filter surface	42 cm ²
Filter mesh	2 µm
Dead volume	28.5 ml
Materials	
Filter:	PTFE, PVDF, Duran glass (parts in contact with mediums)
Seal:	Viton
Filter element:	sintered PTFE

Performance data

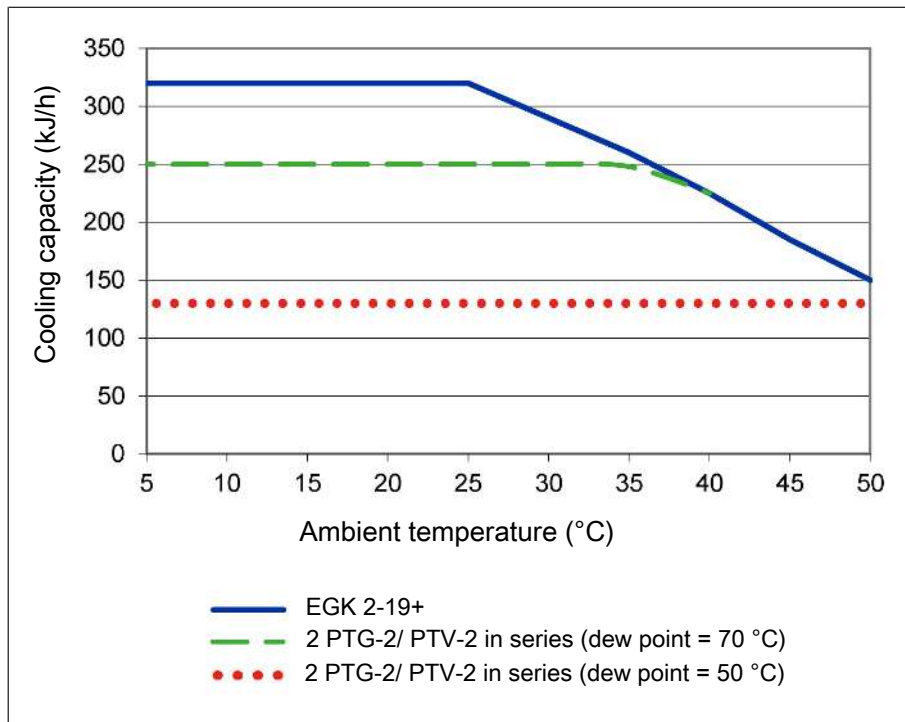

Remark: The limit curves for the heat exchanger apply to a dew point of 70 °C under standard conditions per DIN EN 15267-3:2008-03 and to a dew point of 50 °C under operating conditions.

Heat exchanger description

The energy content of the sample gas and the required cooling capacity of the gas cooler is determined by three parameters: gas temperature ϑ_G , dew point τ_e (moisture content) and volume flow v . The outlet dew point rises with increasing energy content of the gas. The following limits for the maximum flow are specified for a standard operating point of $\tau_e = 40$ °C and $\vartheta_G = 70$ °C. The maximum flow v_{\max} in NI/h of cooled air indicated, so after moisture has condensed. Values may differ for other dew points and gas inlet temperatures. However, the physical facts are so vast we decided to omit the illustration. Please contact our experts for clarification or refer to our calculation programme.

Heat exchanger overview

Heat exchanger	2x PTG-2 2x PTG-2-I ²⁾	2x PTV-2 2x PTV-2-I ²⁾
Materials in contact with media	DURAN® glass PTFE	PVDF
Flow rate v_{\max} ¹⁾	250 NI/h	250 NI/h
Inlet dew point $\tau_{e,\max}$ ¹⁾	70 °C	70 °C
Gas inlet temperature $\vartheta_{G,\max}$ ¹⁾	140 °C	140 °C
Max. Cooling capacity Q_{\max}	230 kJ/h	215 kJ/h
Gas pressure p_{\max}	3 bar	2 bar
Pressure drop Δp ($v=150$ L/h) total	20 mbar	20 mbar
Dead volume V_{tot} total	59 ml	115 ml
Gas connections (metric)	GL 14 (6 mm) ³⁾	DN 4/6
Gas connections (US)	GL 14 (1/4") ³⁾	1/4"-1/6"
Condensate out connections (metric)	GL 25 (12 mm) ³⁾	G3/8
Condensate out connections (US)	GL 25 (1/2") ³⁾	NPT 3/8"

¹⁾ Max. cooling capacity of the cooler must be considered.

²⁾ Models marked I have NPT threads or US tubes, respectively.

³⁾ Gasket inside diameter.

Dimensions (mm)

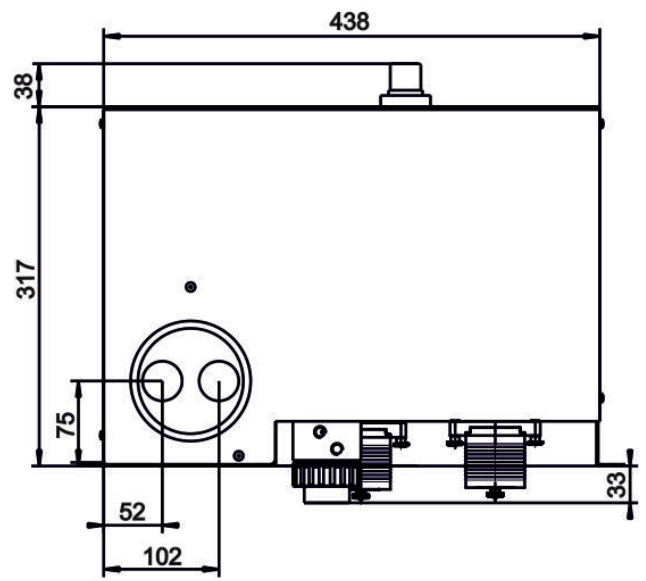
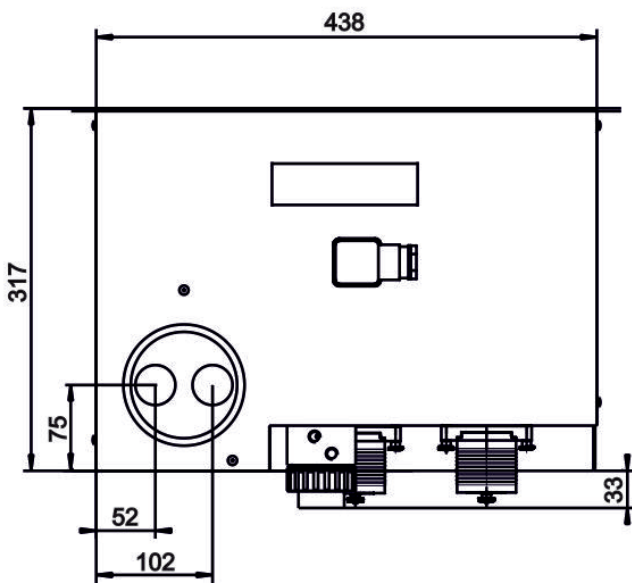
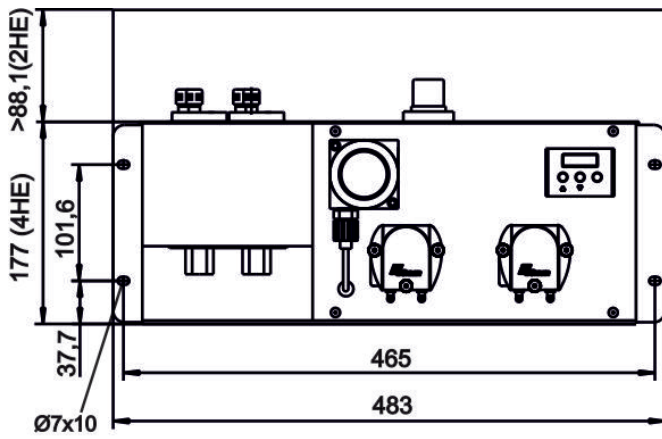

Ordering instructions

Gas cooler type with two heat exchangers in series

The item number is a code for the configuration of your unit. Please use the following model key:

452	X	X	X	X	X	X	X	X	X	0	Product characteristic
											Gas cooler models (with 2 heat exchangers)
										0	Wall mounting
										1	19" rack installation
											Supply voltage
										1	115 V metric screw connections
										2	230 V metric screw connections
										3	115 V US screw connections
										4	230 V US screw connections
											Heat exchanger
										0 0	Without heat exchanger
										1 6	2 single glass heat exchangers/ (2x PTG-2)
										1 7	2 single PVDF heat exchangers/ (2x PTV-2 or PTV-2-I)
											Condensate drain
										0	Without condensate drain
										2	2 CPsingle peristaltic pumps with 90° angle hose connection ¹⁾
										4	2 CPsingle peristaltic pumps with straight hose connection ¹⁾
											Filter
										0	Without filter
										1	1 filter installed
											Moisture detector ²⁾
										0	Without moisture detector
										1	1 moisture detector installed (only possible with 1 filter)
											Optional ²⁾
										0	Without option
										1	With 4 - 20 mA analogue output for temperature

¹⁾ Each heat exchanger is equipped with one peristaltic pump. The supply voltage corresponds with that of the main unit.

²⁾ The "moisture detector" option includes the option "4 - 20 mA analogue output".

Spare parts and accessories

Item no.	Description
41151050	Filter element FE-4; Unit 8 count
4101003	O-ring for filter AGF-FA-5, Unit 8 count, sintered PTFE