

Sample gas probe GAS 222.11

In many applications gas analysis is the key for safe and efficient control of process flows, environmental protection and quality assurance. In extractive gas analysis the location of the gas sampling point is crucial for the reproducibility and accuracy of the analysis results.

The specific filter capacity, corrosion resistance and functional equipment requirements for the probe arise from the composition of the sample gas.

However, operating costs are also an important criterion in the selection, as the sampling points are frequently located at hard to access points in the system. Effective particle filter backwashing options and low maintenance characterise the extensive GAS probe series.

Unheated probe with shut-off valve and/or upstream filter

The filter element can easily be removed by turning the handle 90°

For dust loads up to 2 g/m³, non-condensable gases. Combined with upstream filter up to 10 g/m³ and higher

The probe is suitable for use in explosive areas



Flow chart

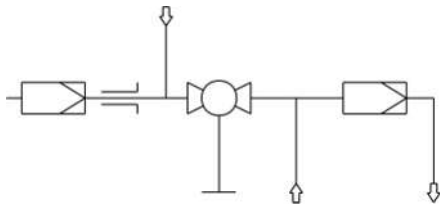

Technical Data

Gas Probe Technical Data

Probe operating temperature:	max. 200 °C	
Ambient temperature without accessories:	-20 to +80 °C	
Ambient temperature with accessories:	Component	Ambient temperature range
	Compressed air valve:	-10 °C < T _{amb} < +55 °C
	Pneumatic drive:	-20 °C < T _{amb} < +80 °C
	Limit switch:	-20 °C < T _{amb} < +100 °C
	Solenoid valve for pneumatic drive:	-10 °C < T _{amb} < +55 °C
Medium temperature (blowback):	Component	Medium temperature range
	Compressed air valve:	-10 °C to +80 °C
	Solenoid valve for pneumatic drive:	-10 °C to +100 °C
Max. operating pressure:	6 bar	
Materials in contact with media		
Flange:	Stainless steel 1.4571	
Probe body:	Stainless steel 1.4571	
Ball valve:	Stainless steel 1.4408/1.4462/PTFE	
Seal:	Stainless steel 1.4404/graphite/and see filter	

Ordering Instructions

The item number is a code for the configuration of your unit. Please use the following model key:

4622211	X	9	9	0	0	X	0	0	X	X	X	X	X	X	X	X	Product Characteristics									
																	Flange									
																	0	DIN DN65 PN6								
																		2	ANSI 3"-150 lbs - without CSA C & US approval							
																			Power supply sample probe							
																			0	none						
																				Calibrating gas connection						
																				0	No calibrating gas connection					
																				1	6 mm					
																				2	6 mm + check valve					
																				3	1/4"					
																				4	1/4" + check valve					
																					Connection heated extension					
																				0	No					
																						Built-in temperature controller for heated extension				
																						0	No			
																							Blowback with air reservoir ¹⁾			
																							Air reservoir heating			
																							1	Yes		
																							9	No		
																								Built-in blowback control		
																							9	No		
																								Compressed air valve / valve voltage information		
																								0	Manual	
																								1	115 V	
																								2	230 V	
																								3	24 V	
																								9	None (if no blowback requested)	
																									Pneumatic drive for ball valve	
																								0	Manual	
																								1	Monostable pressure-free open	
																								2	Monostable pressure-free closed	
																								3	Bi-stable	
																									Limit switch for pneumatic drive	
																								1	Yes	
																								9	No	
																									Control valve for pneumatic drive	
																									3	3/2-way valve
																									5	5/2-way valve
																									9	No control valve

¹⁾ In the case of flammable gases, always use inert gas for blowback. Probe blowback prohibited when using explosive sample gas!

Options

The base unit becomes functional by adding accessories suitable for the application. Please refer to accessory data sheet no. 461099 for information.

Please also refer to data sheet no. 461000 "GAS 222 Gas Probes" for a general description.

Dimensions

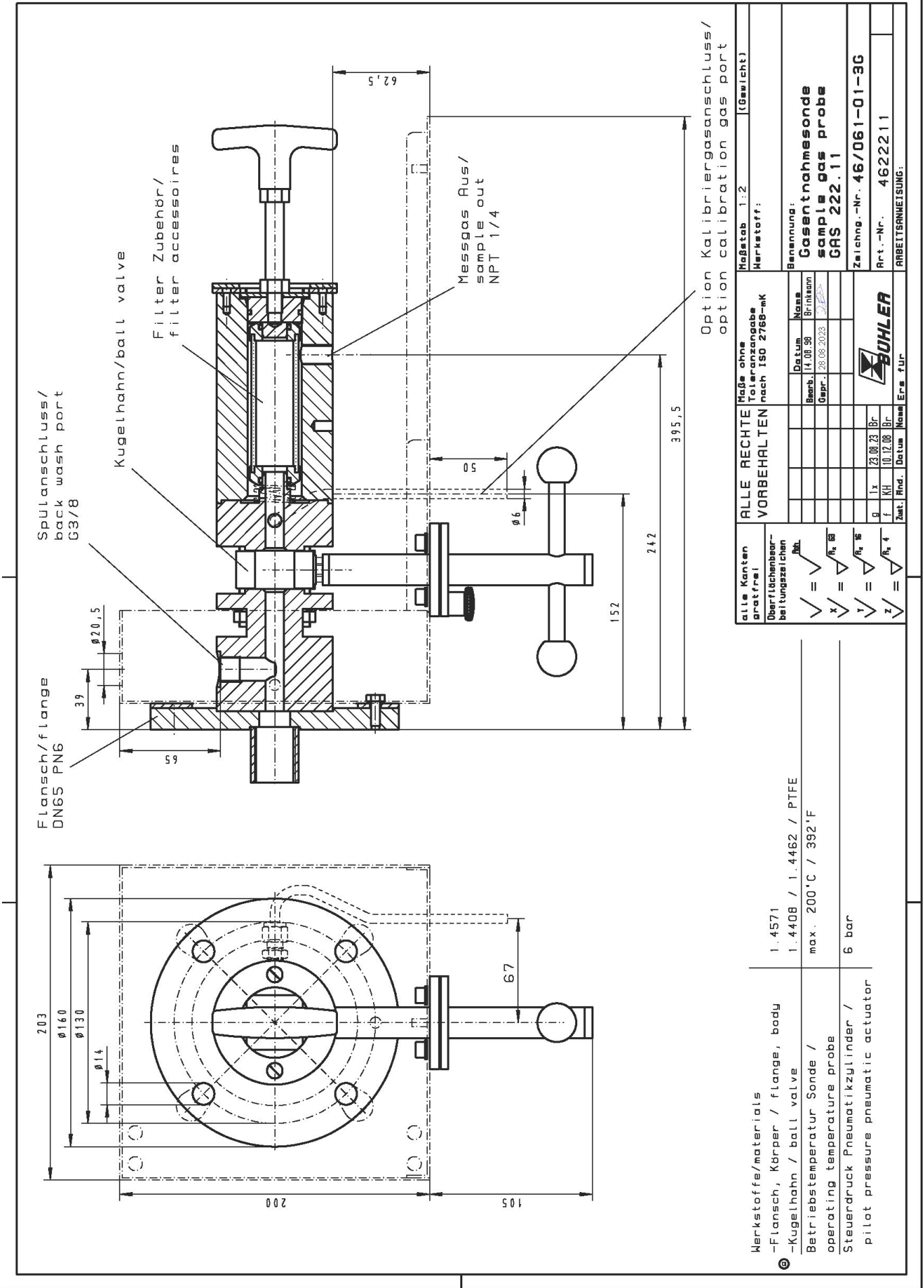

Werkstoffe/materials	1.4571
-Flansch, Körper / flange, body	1.4408 / 1.4462 / PTFE
-Kugelhahn / ball valve	max. 200 °C / 392 °F
Betriebstemperatur Sonde / operating temperature probe	6 bar
Steuerdruck Pneumatikzylinder / pilot pressure pneumatic actuator	

alle Kanten pratfrei	<input checked="" type="checkbox"/>
Oberflächenbear- beitungszeichen	<input checked="" type="checkbox"/>
h ₁	<input checked="" type="checkbox"/>
h ₂	<input checked="" type="checkbox"/>
h ₃	<input checked="" type="checkbox"/>
h ₄	<input checked="" type="checkbox"/>

ALLE RECHTE VORBEHALTEN	Maße ohne Toleranzangabe nach ISO 2768-mK
	Bearb. 14.08.99 Brinkmann
	Gepr. 28.08.2023
	Datum Name
	g 1x 23.08.23 Br
	f KH 10.12.08 Br
	Zust. End. Datum Name Ers für

Maßstab 1:2 (Gewicht)	Herbstoff:
Benennung:	Gasentnahmesonde
	sample gas probe
	GAS 222.11
Zeichn.-Nr. 46/061-01-3G	
Art.-Nr. 4622211	
ARBEITSAUSSAGE:	

Dimensions (ANSI flange)

NOTICE! ANSI flange only available without CSA approval.

